

Setting up MLA-200s

Each MLA-200 in an audio network is differentiated by the unique ID that is specified. Specify this ID with the DIP switch.

1. With nothing connected, open the DIP switch cover on the rear panel. One side of the cover remains attached. Disengage the side that does not remain attached, and then slowly open the cover.

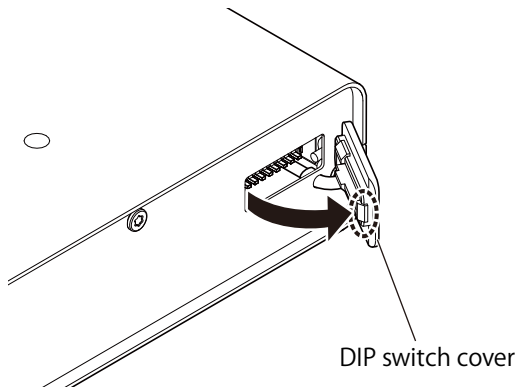

2. Set the DIP switch.

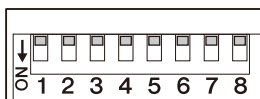

The switches of the DIP switch are set to ON when it is down and OFF when it is up. As a default, all switches are set to OFF (up).

NOTE

Be sure to view the DIP switch in its proper orientation.

Set the DIP switch for each MLA-200 according to the following table.

Instructor and students 1 to 24 (MRX7-D ID=1)

	SW							
	1	2	3	4	5	6	7	8
Instructor (ID=1)	OFF	OFF	OFF	OFF	OFF	OFF	OFF	ON
Student 1 (ID=2)	OFF	OFF	OFF	OFF	OFF	OFF	ON	OFF
Student 2 (ID=3)	OFF	OFF	OFF	OFF	OFF	OFF	ON	ON
Student 3 (ID=4)	OFF	OFF	OFF	OFF	OFF	ON	OFF	OFF
Student 4 (ID=5)	OFF	OFF	OFF	OFF	OFF	ON	OFF	ON
Student 5 (ID=6)	OFF	OFF	OFF	OFF	OFF	ON	ON	OFF
Student 6 (ID=7)	OFF	OFF	OFF	OFF	OFF	ON	ON	ON
Student 7 (ID=8)	OFF	OFF	OFF	OFF	ON	OFF	OFF	OFF
Student 8 (ID=9)	OFF	OFF	OFF	OFF	ON	OFF	OFF	ON

Student 9 (ID=10)	OFF	OFF	OFF	OFF	ON	OFF	ON	OFF
Student 10 (ID=11)	OFF	OFF	OFF	OFF	ON	OFF	ON	ON
Student 11 (ID=12)	OFF	OFF	OFF	OFF	ON	ON	OFF	OFF
Student 12 (ID=13)	OFF	OFF	OFF	OFF	ON	ON	OFF	ON
Student 13 (ID=14)	OFF	OFF	OFF	OFF	ON	ON	ON	OFF
Student 14 (ID=15)	OFF	OFF	OFF	OFF	ON	ON	ON	ON
Student 15 (ID=16)	OFF	OFF	OFF	ON	OFF	OFF	OFF	OFF
Student 16 (ID=17)	OFF	OFF	OFF	ON	OFF	OFF	OFF	ON
Student 17 (ID=18)	OFF	OFF	OFF	ON	OFF	OFF	ON	OFF
Student 18 (ID=19)	OFF	OFF	OFF	ON	OFF	OFF	ON	ON
Student 19 (ID=20)	OFF	OFF	OFF	ON	OFF	ON	OFF	OFF
Student 20 (ID=21)	OFF	OFF	OFF	ON	OFF	ON	OFF	ON
Student 21 (ID=22)	OFF	OFF	OFF	ON	OFF	ON	ON	OFF
Student 22 (ID=23)	OFF	OFF	OFF	ON	OFF	ON	ON	ON
Student 23 (ID=24)	OFF	OFF	OFF	ON	ON	OFF	OFF	OFF
Student 24 (ID=25)	OFF	OFF	OFF	ON	ON	OFF	OFF	ON

Students 25 to 48 (MRX7-D ID=2)

	SW							
	1	2	3	4	5	6	7	8
Student 25 (ID=26)	OFF	OFF	OFF	ON	ON	OFF	ON	OFF
Student 26 (ID=27)	OFF	OFF	OFF	ON	ON	OFF	ON	ON
Student 27 (ID=28)	OFF	OFF	OFF	ON	ON	ON	OFF	OFF
Student 28 (ID=29)	OFF	OFF	OFF	ON	ON	ON	OFF	ON
Student 29 (ID=30)	OFF	OFF	OFF	ON	ON	ON	ON	OFF
Student 30 (ID=31)	OFF	OFF	OFF	ON	ON	ON	ON	ON
Student 31 (ID=32)	OFF	OFF	ON	OFF	OFF	OFF	OFF	OFF
Student 32 (ID=33)	OFF	OFF	ON	OFF	OFF	OFF	OFF	ON
Student 33 (ID=34)	OFF	OFF	ON	OFF	OFF	OFF	ON	OFF
Student 34 (ID=35)	OFF	OFF	ON	OFF	OFF	OFF	ON	ON
Student 35 (ID=36)	OFF	OFF	ON	OFF	OFF	ON	OFF	OFF
Student 36 (ID=37)	OFF	OFF	ON	OFF	OFF	ON	OFF	ON
Student 37 (ID=38)	OFF	OFF	ON	OFF	OFF	ON	ON	OFF
Student 38 (ID=39)	OFF	OFF	ON	OFF	OFF	ON	ON	ON
Student 39 (ID=40)	OFF	OFF	ON	OFF	ON	OFF	OFF	OFF
Student 40 (ID=41)	OFF	OFF	ON	OFF	ON	OFF	OFF	ON

Student 41 (ID=42)	OFF	OFF	ON	OFF	ON	OFF	ON	OFF
Student 42 (ID=43)	OFF	OFF	ON	OFF	ON	OFF	ON	ON
Student 43 (ID=44)	OFF	OFF	ON	OFF	ON	ON	OFF	OFF
Student 44 (ID=45)	OFF	OFF	ON	OFF	ON	ON	OFF	ON
Student 45 (ID=46)	OFF	OFF	ON	OFF	ON	ON	ON	OFF
Student 46 (ID=47)	OFF	OFF	ON	OFF	ON	ON	ON	ON
Student 47 (ID=48)	OFF	OFF	ON	ON	OFF	OFF	OFF	OFF
Student 48 (ID=49)	OFF	OFF	ON	ON	OFF	OFF	OFF	ON

Students 49 to 72 (MRX7-D ID=3)

	SW							
	1	2	3	4	5	6	7	8
Student 49 (ID=50)	OFF	OFF	ON	ON	OFF	OFF	ON	OFF
Student 50 (ID=51)	OFF	OFF	ON	ON	OFF	OFF	ON	ON
Student 51 (ID=52)	OFF	OFF	ON	ON	OFF	ON	OFF	OFF
Student 52 (ID=53)	OFF	OFF	ON	ON	OFF	ON	OFF	ON
Student 53 (ID=54)	OFF	OFF	ON	ON	OFF	ON	ON	OFF
Student 54 (ID=55)	OFF	OFF	ON	ON	OFF	ON	ON	ON
Student 55 (ID=56)	OFF	OFF	ON	ON	ON	OFF	OFF	OFF
Student 56 (ID=57)	OFF	OFF	ON	ON	ON	OFF	OFF	ON
Student 57 (ID=58)	OFF	OFF	ON	ON	ON	OFF	ON	OFF
Student 58 (ID=59)	OFF	OFF	ON	ON	ON	OFF	ON	ON
Student 59 (ID=60)	OFF	OFF	ON	ON	ON	ON	OFF	OFF
Student 60 (ID=61)	OFF	OFF	ON	ON	ON	ON	OFF	ON
Student 61 (ID=62)	OFF	OFF	ON	ON	ON	ON	ON	OFF
Student 62 (ID=63)	OFF	OFF	ON	ON	ON	ON	ON	ON
Student 63 (ID=64)	OFF	ON	OFF	OFF	OFF	OFF	OFF	OFF
Student 64 (ID=65)	OFF	ON	OFF	OFF	OFF	OFF	OFF	ON
Student 65 (ID=66)	OFF	ON	OFF	OFF	OFF	OFF	ON	OFF
Student 66 (ID=67)	OFF	ON	OFF	OFF	OFF	OFF	ON	ON
Student 67 (ID=68)	OFF	ON	OFF	OFF	OFF	ON	OFF	OFF
Student 68 (ID=69)	OFF	ON	OFF	OFF	OFF	ON	OFF	ON
Student 69 (ID=70)	OFF	ON	OFF	OFF	OFF	ON	ON	OFF
Student 70 (ID=71)	OFF	ON	OFF	OFF	OFF	ON	ON	ON
Student 71 (ID=72)	OFF	ON	OFF	OFF	ON	OFF	OFF	OFF
Student 72 (ID=73)	OFF	ON	OFF	OFF	ON	OFF	OFF	ON

Students 73 to 96 (MRX7-D ID=4)

	SW							
	1	2	3	4	5	6	7	8
Student 73 (ID=74)	OFF	ON	OFF	OFF	ON	OFF	ON	OFF
Student 74 (ID=75)	OFF	ON	OFF	OFF	ON	OFF	ON	ON
Student 75 (ID=76)	OFF	ON	OFF	OFF	ON	ON	OFF	OFF
Student 76 (ID=77)	OFF	ON	OFF	OFF	ON	ON	OFF	ON
Student 77 (ID=78)	OFF	ON	OFF	OFF	ON	ON	ON	OFF
Student 78 (ID=79)	OFF	ON	OFF	OFF	ON	ON	ON	ON
Student 79 (ID=80)	OFF	ON	OFF	ON	OFF	OFF	OFF	OFF
Student 80 (ID=81)	OFF	ON	OFF	ON	OFF	OFF	OFF	ON
Student 81 (ID=82)	OFF	ON	OFF	ON	OFF	OFF	ON	OFF
Student 82 (ID=83)	OFF	ON	OFF	ON	OFF	OFF	ON	ON
Student 83 (ID=84)	OFF	ON	OFF	ON	OFF	ON	OFF	OFF
Student 84 (ID=85)	OFF	ON	OFF	ON	OFF	ON	OFF	ON
Student 85 (ID=86)	OFF	ON	OFF	ON	OFF	ON	ON	OFF
Student 86 (ID=87)	OFF	ON	OFF	ON	OFF	ON	ON	ON
Student 87 (ID=88)	OFF	ON	OFF	ON	ON	OFF	OFF	OFF
Student 88 (ID=89)	OFF	ON	OFF	ON	ON	OFF	OFF	ON
Student 89 (ID=90)	OFF	ON	OFF	ON	ON	OFF	ON	OFF
Student 90 (ID=91)	OFF	ON	OFF	ON	ON	OFF	ON	ON
Student 91 (ID=92)	OFF	ON	OFF	ON	ON	ON	OFF	OFF
Student 92 (ID=93)	OFF	ON	OFF	ON	ON	ON	OFF	ON
Student 93 (ID=94)	OFF	ON	OFF	ON	ON	ON	ON	OFF
Student 94 (ID=95)	OFF	ON	OFF	ON	ON	ON	ON	ON
Student 95 (ID=96)	OFF	ON	ON	OFF	OFF	OFF	OFF	OFF
Student 96 (ID=97)	OFF	ON	ON	OFF	OFF	OFF	OFF	ON

This completes the setup of the MLA-200s.