



Drums

HANDCRAFTED SINCE 1967



U.S.A.
<http://www.yamahadrums.com>
EUROPE
<http://www.yamaha-europe.com>
U.K.
<http://www.yamaha-music.co.uk>
JAPAN(DTX,DTXPRESS)
<http://www.yamaha.co.jp/english/product/drum/dtx/index.html>



Drums

HANDCRAFTED SINCE 1967

*Some models may not be available in some countries.
*Colors shown in this catalog may not be represented exactly as the original colors due to printing processes involved.
*Specifications are subject to change without notice.

 PRINTED WITH SOY INK This document is printed on chlorine-free(ECF)paper with soy ink.

LDR0903CB



Printed in Japan

P10021502

In 2007, we celebrated our 40th anniversary in manufacturing drums with the introduction of the PHX Series drums—a high-end series that brings together the knowledge and skills we've gained over the past 40 years making drums. Since their introduction these drums have received high acclaim from professional drummers who are serious about their sound. They have also proven that drums, as musical instruments, can be improved upon.

For 2009, we are introducing an all-new Absolute Series. Redesigned from the ground up, these drums inherit the concepts and skills acquired in the design of our PHX Series. Even the hardware has been redesigned in order to provide the utmost in operability, stability, and durability.

Select materials, precision processing, acoustically engineered designs and the skills of our master craftsmen.

With these resources at our disposal, we turned to drummers for their valuable insight and began building numerous prototypes in our quest to design the best drums possible.

Driven to deliver the best in musical instruments, we continue setting our sights higher in our search for perfection.



INDEX

| | | | | | | | |
|-------------------------|----|----------------------------|----|------------------------------|----|-------------------------|----|
| INTRO INDEX | 1 | Hippig Sr. | 20 | Wood Snare Series | 29 | Double Tom Stands | 48 |
| TOTAL CONCEPT | 2 | Junior Kit | 20 | Metal Snare Series | 31 | HEXRACK | 49 |
| SYSTEM DRUMS | | Subkick | 21 | Sigunature Snare Series | 33 | ELECTRONIC DRUMS | |
| PHX Series | 5 | Wedges | 21 | DRUMMERS IN THE WORLD | 35 | DTXTREME III | 51 |
| Absolute Series | 7 | DAXDAD | 21 | HARDWARE | | DTXPRESS IV | 53 |
| Recording Custom | 11 | Club Jordan | 22 | Foot Pedals | 40 | DTXPLOER | 55 |
| Oak Custom | 13 | SNARE DRUMS | | Hi-hat Stands | 43 | DTX PAD | 57 |
| Tour Custom | 15 | Philosophy of the | | Cymbal Stands | 45 | Misc. | 59 |
| Stage Custom | 17 | Yamaha Snare Drums | 23 | Snare Stands | 47 | FACTORY PARTS | 60 |
| SIGNATURE SERIES | | Yamaha Snare Drums LINE UP | 25 | Drum Stools | 47 | | |
| Hippig | 19 | New Concept Series Snare | 27 | Tom Holders | 48 | | |

Yamaha—Drum Manufacturing with Tradition

Bass Drum "R-Version"

When using a rack system or for musicians who don't want to obstruct the tonality of the bass drum by mounting a tom, the "R-Version" Bass Drum has been introduced to the PHX Series and Absolute Series. Now you can experience every bit of that pure bass drum sound. (for PHX Series, Absolute Series, Oak Custom)

Bass Drum Spurs

The result of years of refinement, Yamaha bass drum legs prevent bass drums from creeping forward, in most instances without carpets or tacky underlays. Quick and easy to use, Yamaha bass drum legs keep bass drums rigid and immovable, even under the hardest pounding. Thicker tubing, combined with drum key operated height adjustability and easy-slide metal points, as found on our cymbal stands, provide enhanced stability.

Ball Mount & Clamp

A tribute to Yamaha design technology, our original ball mount and clamp has gone through very few modifications over the years. A large, ultra-hard resin ball sits in an attractive chromed housing, held in place with a titanium ergonomic wing bolt. It is the ultimate drummer-friendly mount, offering non-slip positioning virtually anywhere the drummer can imagine. Additionally, it permits tuning of the bottom head by simply rotating the drum.

Vent Holes

The number of vent holes influences both the drum's timbre and projection. PHX Series and New Absolute Series are designed with one to ten vent holes, depending upon the drum's dimensions. By varying the number of holes, particularly on larger shells, the drum's sustain length, amount of mid-bass tone, and playing comfort can all be fine-tuned.

Floating Bass Drum System

A pipe post stabilizer on the pedal side of the bass drum provides height adjustment and positions the beater so that it strikes the center of the bass drum batter head. A memory clamp on the pipe slides into a special receiver on the bottom of the bass drum, allowing for quick set up and exact height retention. (for Absolute Series, Oak Custom)





“Air Seal System” Technology

At Yamaha, the process of manufacturing drum shells begins with the selection of the materials. Select woods are cut into sheets with precision cut diagonal ends. The plies are fit into a form and hammered into place by a highly skilled craftsman. The angled ends allow the craftsman to finely adjust the ply length, thus maintaining proper tension. Ply joints are staggered by 120-degrees and hammered into place in the same manner. An air bag placed inside of the shell and inflated at high-pressure puts even pressure on the shell's inner surface creating a perfectly round shell with uniform thickness and excellent durability. This is the Air Seal System, a process that has been in use at Yamaha for over 40 years.

Shell Materials



MAPLE

Hard, dense maple delivers a warm tone with outstanding sustain and is considered an excellent material for making drums. Yamaha goes to great lengths, sorting the woods into finer grades and using them accordingly. Maple produces a versatile tone that blends well with a wide range of musical styles, making it popular with drummers from all over the world.

BIRCH

Yamaha's use of birch is longstanding. Remarkably easy to work with, this hard, finely grained wood offers excellent mid and low sustain with a solid, well-defined high range. Our original “Recording Custom” drums are made from birch grown in Hokkaido Japan.

OAK

Yamaha has developed special techniques for employing oak, previously considered unworkable for drums. Our oak shells offer tone that is at once loud, sensitive, ringing, clean, and vibrant. While its inherent power makes it the ideal heavy metal drum shell, its stark clarity at low volumes have made it a new discovery for jazz players. Oak is as individual as the drummer playing it.

Hybrid Shell Construction for PHX Series (Patent Pending)

With the wealth of knowledge that YAMAHA has amassed through the decades as the preeminent maker of musical instruments, YAMAHA's wood specialists have discovered new materials that provide optimal drum performance.

Jatoba, a Brazilian wood and the hardest material in the PHX hybrid shell, is positioned as the core ply and center note of the drum. It is surrounded on either side by layers of kapur, a Malaysian hard wood. North American Maple, which had long been considered a classic, high-quality drum shell material because of its hardness and viscosity, is actually the softest wood in the shell construction; maple is the outer and inner plies of the shell.

This is the process used to complete the hybrid shell, in which the stiffness of the shell shifts from the center toward the outside: the woods are hardest at the center and get softer toward the outer surfaces in either direction. This results in an “excitation structure” that maximizes the shell's performance. The excitation structure increases the head's vibration to its full extent, achieving a sound unlike anything you've heard before. It produces an effect in sound waves similar to rippling waves caused by a pebble dropped in water.

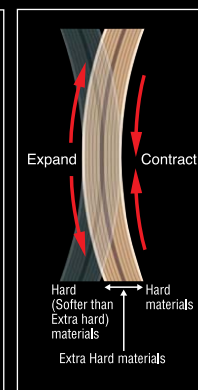
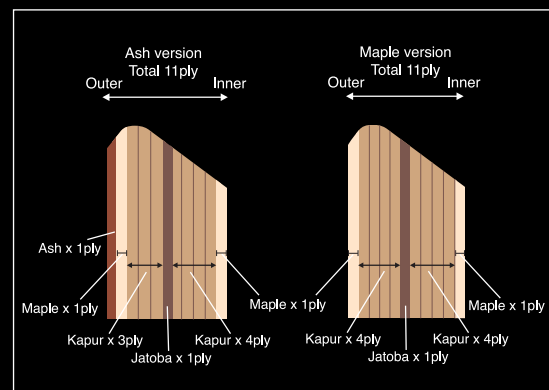

* The excitation structure increases shell vibration to its maximum through the use of relatively softer materials for the external and internal surface areas, whose curvature is greatest when the shell is vibrating, as well as by using a hard material with a high “spring” property for the core of the shell lamination.

High Performance Lugs

Yamaha lug casings hold tension rods firmly in place. They afford precise tuning in the smallest increments and do not slip. From our truly innovate Hook Lugs which offer lightning quick changes, to fixed small lugs. (Absolute and Oak Custom lugs) Each is low mass and is designed to promote optimum shell resonance. Our legendary one-piece high-tension lugs are precision-machined to allow severe, high tension tuning also reinforced the shell.

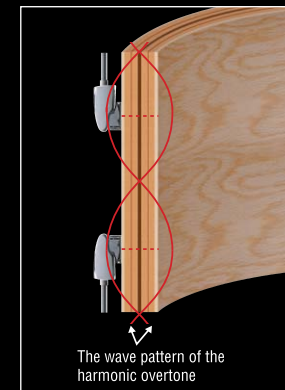

Hook Lug



Small Lug



High Tension Lug



Yamaha Enhanced Sustain System—YESS

The secret of our YESS system is twofold: First, it provides minimum contact of hardware with shell; second, it connects that hardware at the nodal point* of the drum—the point at which it will not interfere with shell vibration. Nylon bushings on rod clamps afford maximum stability. The YESS system permits toms to be placed close together, and does not interfere with quick head changes. On floor toms, our YESS system offers wide open sustain while keeping toms stable under the heaviest strokes. The newly evolved YESS II Shell Mounting System makes the most of the shell's vibration. Employing a special new rubber material and the “wood plate mounting” method, vibrations from the shell and hardware can be separated, thus minimizing unwanted resonance. Also, by positioning a part of that special rubber material at the belly area (where overtones are present) while most of them are positioned at the nodal point, the appropriate amounts of sustain and overtone control are simultaneously produced.

And also new ly evolved YESS II-m is using same technology but using metal plate instead of wood plate.

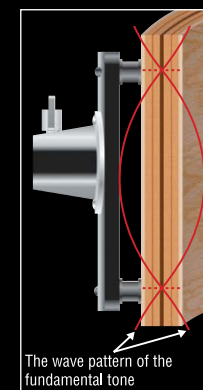

YESS II



YESS II-m

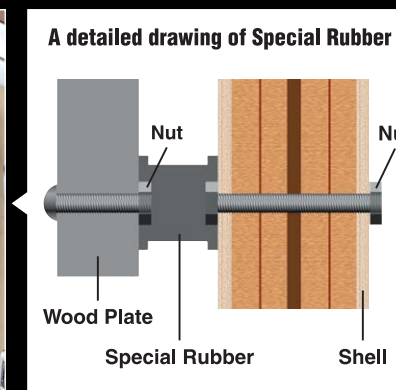

YESS

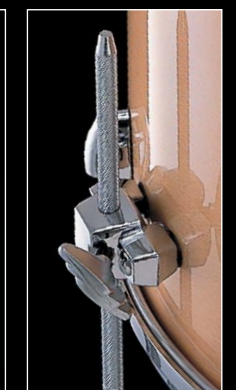
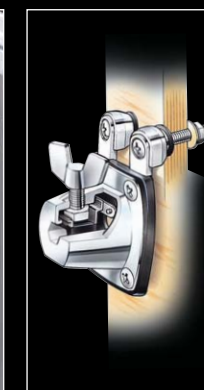

PHX Series

The PHX Series, from the YAMAHA Drum Laboratory

At YAMAHA, prototype drums are the starting point of each drum's evolution. These prototypes are created in the Drum Laboratory where YAMAHA continually pursues the essence of musical perfection.

Under a completely new concept, the PHX (pronounced "phoenix") Series is the pinnacle of excellence in this prototyping process. Handcrafted by our expert technicians, it's based on over 40 years of history, tradition, experience, and technology. The newly developed PHX Series reveals YAMAHA's all-out pursuit of the ultimate in drum craftsmanship and sound.



Shells

PHXB2418MR
PHXF1615M
PHXF1413M
PHXT1310M
NSD1455

Hardware

CS845x4
WS865x2
CH750x2
SS840
DS840
HS950
FP9315x2

 Polar White

A Range of Options

In addition to the qualities of tonality and functionality, YAMAHA has paid special attention to the values of interior and exterior beauty. The exterior of the PHX shell is available in classic maple or exotic burlled ash finishes. Further, the Hook Lugs and aluminum die-cast hoops are available in either gold or chrome options. Experience the ultimate combination of unparalleled beauty with brilliant color finishes, including the fresh and unique textured paint.



PHX badge with Phoenix



With Gold Parts



With Chrome Parts

Bearing Edge Shape

To control the drum's tone and articulation, PHX floor tom, tom-tom and bass drum shells each use different types of bearing edges. All bearing edge angles are set at 30-degrees. However, the radiuses of the bearing edges differ to gain optimum acoustic performance from the shell. Additionally, a secret treatment process is used to ensure that each edge is finished to a perfect smoothness. This guarantees a very easy and wide tuning range.

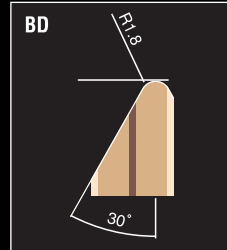
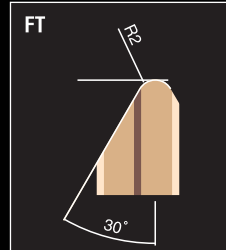
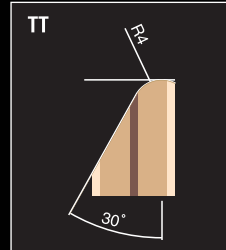

Shells

PHXB2216AGR
PHXT1613AG
PHXT1411AG
PHXT1209AG
PHXT1008AG
PHXT0807AG
VSD1460

Hardware

CH755x4
CH750x2
HS1000
SS840
DS840
FP9315
CL945Bx5

Additional

SKRM100

Rack

HXTCx6
HXCCx5
HXBCx3
HXCP44
HXCP36
HXCP24
HXTL23
HXTL33x2

 Textured Amber Sunburst

COLOR FINISHES

| ASH | | MAPLE | | 3 types of surface finish |
|---|---|---|---|---|
| Gloss Finish | Textured Finish | Gloss Finish | Matte Finish | |
| Sapphire Fade (SPF) | Turquoise Fade (TQF) | Black Cherry Sunburst (BCS) | Matte Black (MBL) | |
|  |  |  |  |  |
| Garnet Fade (GNF) | Textured Black Sunburst (TBS) | Polar White (PWH) | Matte Natural (MNT) |  |
|  |  |  |  | |
| | Textured Amber Sunburst (TAS) | | | |
| |  | | | |

SPECIFICATIONS

| Diameter | BD | | | | | | BD (R Version -without Pipe Clamp) | | | | | | |
|-----------|-------------------|----------|----------|----------|----------|----------|------------------------------------|-----------|-------------------|-----------|-----------|-----------|-----------|
| | 24" | | 22" | | 20" | | 24" | | 22" | | 20" | | |
| x Depth | x18" | x16" | x18" | x16" | x18" | 16" | x14" | x18" | x16" | x18" | x16" | x18" | x16" |
| Model No. | PHXB2418 | PHXB2416 | PHXB2218 | PHXB2216 | PHXB2018 | PHXB2016 | PHXB1814 | PHXB2418R | PHXB2416R | PHXB2218R | PHXB2216R | PHXB2018R | PHXB2016R |
| Shell | Hybrid Shell | | | | | | | | | | | | |
| Lug | New Hook Lug | | | | | | | | | | | | |
| Hoop | Wood hoop | | | | | | | | | | | | |
| Head | Batter: PS3 Clear | | | | | | Coated A | | Batter: PS3 Clear | | | | |

| Diameter | FT | | | TT | | | | | | | | | | | |
|-----------|--|----------|----------|----------|----------|----------|----------|----------|----------|----------|----------|----------|----------|----------|----------|
| | 18" | 16" | 14" | 16" | | 14" | | 13" | | 12" | 10" | 8" | | | |
| x Depth | x16" | x15" | x13" | x13" | x14" | x11" | x12" | x9" | x10" | x8" | x9" | x7" | x8" | x7" | 8" |
| Model No. | PHXF1816 | PHXF1615 | PHXF1413 | PHXT1613 | PHXT1614 | PHXT1411 | PHXT1412 | PHXT1309 | PHXT1310 | PHXT1208 | PHXT1209 | PHXT1007 | PHXT1008 | PHXT0807 | PHXT0808 |
| Shell | Hybrid Shell | | | | | | | | | | | | | | |
| Lug | New Hook Lug | | | | | | | | | | | | | | |
| Hoop | Aluminum Diecast Hoop | | | | | | | | | | | | | | |
| Head | Clear Ambassador(Top) / Clear Ambassador(Bottom) | | | | | | | | | | | | | | |

Absolute Series

Yamaha Hand Crafted Drums

High Quality × Customization

Let's begin with a question: What would your ideal drum kit be like? We could put that question to a hundred drummers, and we'd certainly get a hundred different answers. They'd all talk about the tone, buildup, clarity and stick rebound, but each drummer has his or her own tastes and preferences. Even the shell color would be important. With YAMAHA's Absolute Series you can create the ideal drum kit by choosing your favorite elements from our highest-quality materials and components. So, why play just anybody's drum kit when you could have your very own "dream kit"?



Maple x Birch Custom Absolute

■Shells MAB2220R BAF1615 BAF1413 BAT1208
 ■Hardware FP9500Cx2 HS1200D CH750 CH755x4
 CSBW SS950 DS840 CL945B

*Cymbals are not included.

 Burgundy Sparkle

Maple Custom Absolute

■Shells MAB1814 MAF1413 MAT1208
 ■Hardware FP8500B HS740A CS650A CS655Ax2 SS740A
 DS840 TH904A CL945B

*Cymbals are not included.

 Caramel Sparkle



Birch Custom Absolute

■Shells BAB2218HR BAT1412H BAT1411H BAT1209H
 BAT1008H BAT0807H
 ■Hardware DFP9500D HS1200T CH750x2 CH755x4
 CSBW CHH930 SS950 DS840

*Cymbals are not included.

 White Grape Sparkle

Absolute Lug

Our complete specifications are passed on to succeeding model lines, generation after generation. The already well-known "Absolute Lug," for instance, can be firmly secured with a single bolt. It's a complete secure lug that doesn't interfere with vibrations of the shell. The insertion plate, which is located within the lug case, and the nylon ring at the lower part of the lug nut control the slackening of the tuning bolt, providing the utmost in tuning stability.



Hook Lug (Option)

The Hook Lug has been redesigned by thoroughly improving our innovative hook-type Nouveau Lug (used in the conventional Absolute Series) in every aspect. At the same time, the greatness of the lug's basic concept has been maintained. It can be said that the Hook Lug is truly a next-generation lug that transcends conventional lugs with its acoustical effect and tuning stability, as well as with the sturdiness needed for high-tension tuning and the way it facilitates quick head replacement. As with the Absolute Lug, the insertion plate and nylon ring within the lug nut control the slackening of the tuning bolt.



Absolute Series

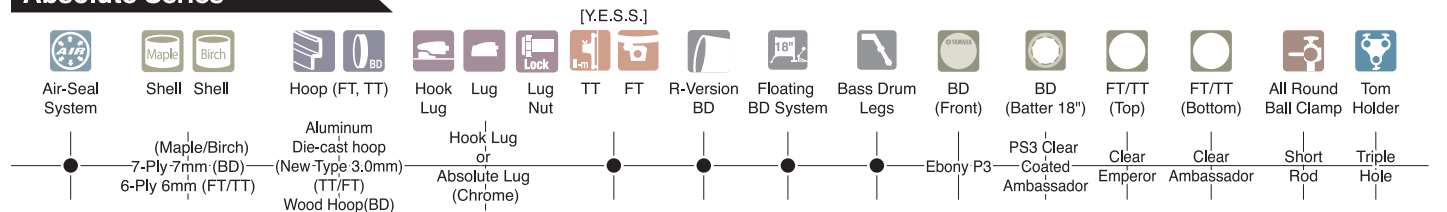

YESS II-m

Y.E.S.S. II is an improved version of YAMAHA's original tom mount, known as the Y.E.S.S. (Yamaha Enhanced Sustain System). Its unique design, which minimizes interference with the shell's natural response—which some call the "rumble"—has been adopted for the PHX Series and is highly praised by pro players worldwide. The Y.E.S.S. II-m model, which uses a metal plate instead of the wood plate found in the Y.E.S.S., has been adopted for the Absolute Series, producing even longer sustain.

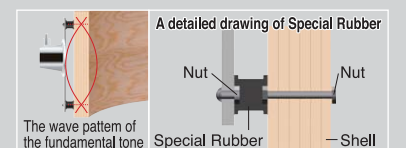

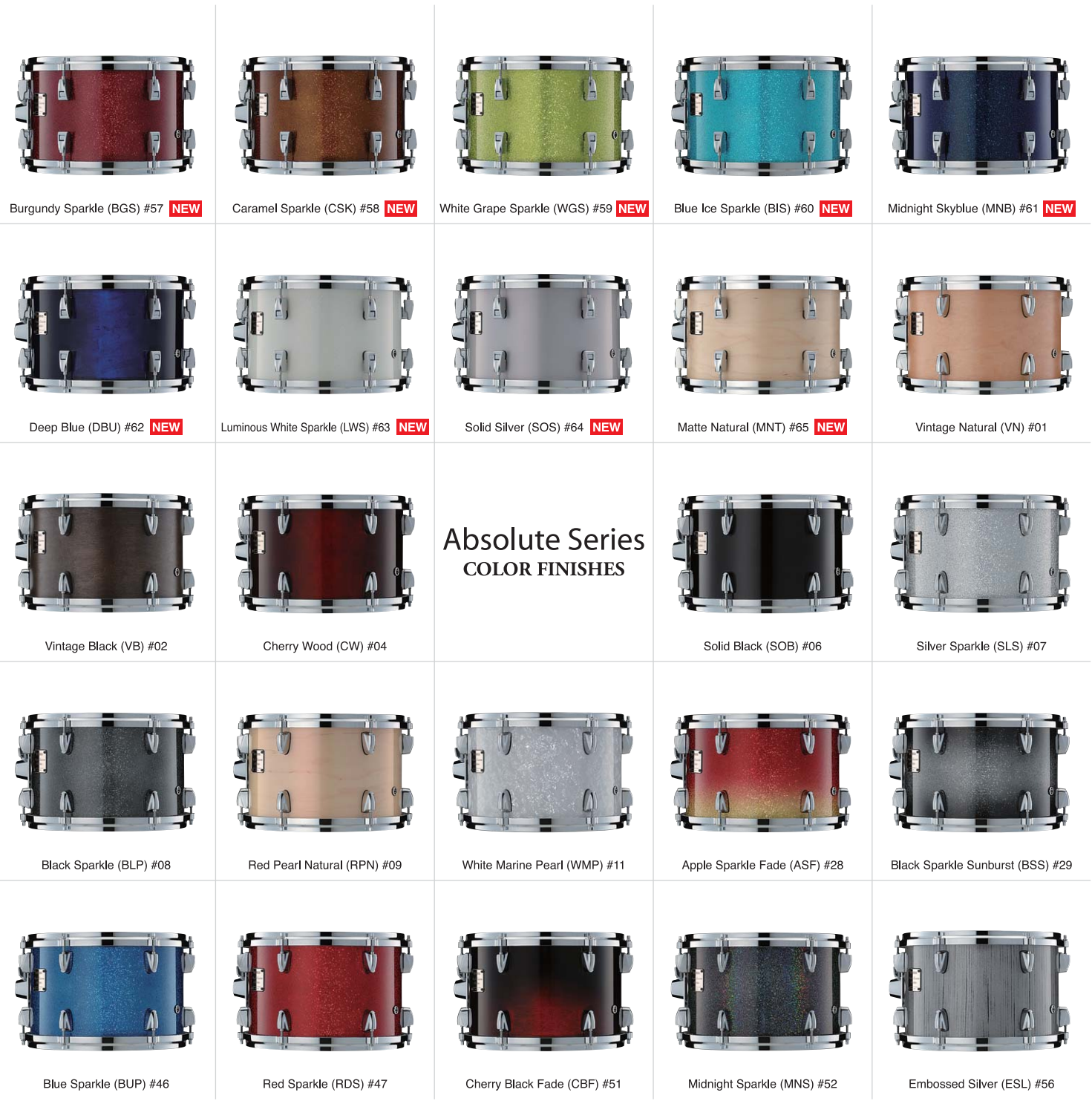

**Absolute Series
COLOR FINISHES**

What is "Vintage Finish"

The Vintage Finish is a special process developed by YAMAHA using a top-quality drum coating material. The use of this unique coating allows us to create a finish that's far thinner but harder than the regular coating material. As a result, it's possible to ensure the maximum vibratory response from the shell and achieve a more brilliant, beautiful appearance. The Vintage Finish coating also protects the shell laminate from humidity. One of its special features is that the color can become even more intense after the coating is applied, depending on the wooden material's surface condition, physical properties of the coating material and other conditions such as ambient temperature and light. Please note that although individual differences in color may occasionally appear depending on the condition of the wooden laminate (which consists of natural materials), the period of purchase and the product's storage condition, it's one of the special features of this coating specification. Therefore, it won't affect the tonality of the product.

Midnight Sparkle

The Midnight Sparkle finish has a black sparkle finish base. Please understand that the colors in this finish change in relation to light conditions and the angle at which you look at the drum, so the actual appearance might differ from that shown in the photo.

Luminous White Sparkle

This newly developed Luminous White Sparkle appears to be a regular white sparkle under normal lighting. But be forewarned: Thanks to a special fluorescent coating, this spectacular finish glows in the dark. Even on a dark stage, your YAMAHA Absolute kit will establish its own unique territory!

Wood

■ **MAPLE**
Carefully selected maple material is used. It offers rich, warm tone and abundant sustain. This material is loved by drummers the world over, and is heard in every musical genre imaginable.

■ **BIRCH**
We use the finest Hokkaido-grown birch material, and it's noted for a fine grain and attractive gloss. Although birch is hard, it has excellent workability. Drummers love its outstanding ability to carry the middle to low tones, as well as its sharp but solid response in the upper register. Birch material is also used for the Recording Custom, which can be considered the foundation of YAMAHA's system drum.

Both the maple and birch shells are available in the seven-ply (BD) and six-ply (FT, TT, SD) specifications. Excellent durability is achieved with the use of premium materials, and through the combination of the air sealing system and YAMAHA's advanced woodworking technologies. The Absolute Series produces a well-balanced rumble. You can choose from a variety of sizes from an 8-inch tom-tom to a 24-inch bass drum.



Vent Hole

The vent hole plays an important role in performance, since it affects not only the sensation of hitting the drum (the impact) but also the initial sound, sustain and tone. Through an exhaustive series of prototypes, YAMAHA has discovered the optimal number and vent hole position depending on the air capacity of each shell. Particularly, vent holes contribute to the enhancement of tone colors in midrange to low-frequency sounds, as well as the control of sustain.

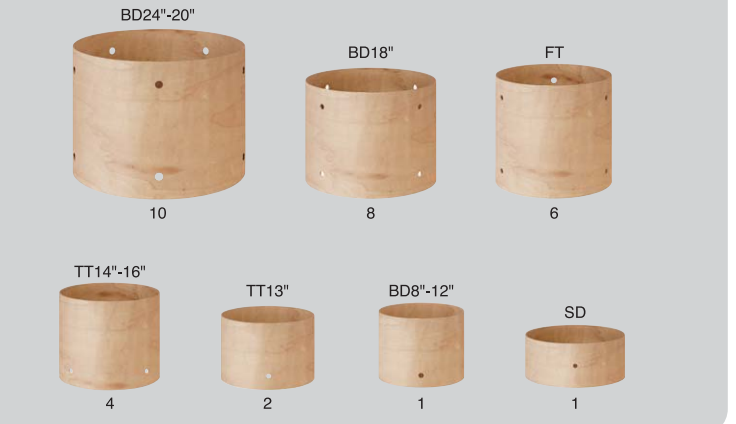

SET LIST

| Series | Set No. | Bass Drum | Floor Tom | Mounted Tom | Hardware |
|--|---------|-----------|-----------|--------------------|----------|
| Maple Custom Absolute Absolute Lug Models | MA2F2 | MAB2218 | MAF1615 | — | TH945B |
| | MA2RF2 | MAB2220R | MAF1615 | — | — |
| | MA2RT2 | MAB2218R | — | MAT1412 | — |
| | MA0F2 | MAB2016 | MAF1413 | — | TH945B |
| | MAT2 | — | — | MAT1209, MAT1008 | — |
| Maple Custom Absolute Hook Lug Models (Option) | MAH2F2 | MAB2218H | MAF1615H | — | TH945B |
| | MAHT2 | — | — | MAT1209H, MAT1008H | — |
| | BA2F2 | BAB2218 | BAF1615 | — | TH945B |
| Birch Custom Absolute Absolute Lug Models | BA2RF2 | BAB2220R | BAF1615 | — | — |
| | BA2RT2 | BAB2218R | — | BAT1412 | — |
| | BA0F2 | BAB2016 | BAF1413 | — | TH945B |
| | BAT2 | — | — | BAT1209, BAT1008 | — |
| | BAH2F2 | BAB2218H | BAF1615H | — | TH945B |
| Birch Custom Absolute Hook Lug Models (Option) | BAHT2 | — | — | BAT1209H, BAT1008H | — |

SPECIFICATIONS

| | | | | | | | |
|-----------------|---|------------|---------|----------------|------------|---------------|----------|
| Lug | Absolute Lug or New Hook Lug (Option) | | | | | | |
| Hoop | Aluminum Die-cast | | | | | | |
| BD Head | Front:Ebony PS3 with YAMAHA Logo, Batter:PS3 Clear (only 18"BD Coated Ambassador) | | | | | | |
| TT/FT Head | Top:Clear Emperor, Bottom:Clear Ambassador | | | | | | |
| SD Head | Top:Coated Ambassador, Bottom:Snare Ambassador | | | | | | |
| Tom Mount | New YESS II-m mount | | | | | | |
| Sound Holes | BD20"-24" 10 | BD18" 8 | FT 6 | TT14"-16" 4 | TT13" 2 | TT8"-12" 1 | SD" 1 |
| Bearing Edge | 45R1 | | | | | | |
| BD Tension Bolt | T-Bolt | | | | | | |

| Maple Custom Absolute | | | | | | | | | | | | | |
|-----------------------|-----------|-------------|-----------|-----------|-------------|-----------|-------------|-----------|-----------|-------------|-----------|-----------|-------------|
| Diameter | 24" | | | 22" | | | 20" | | | 18" | | | |
| | x18" | x16" | x20" | x18" | x16" | x18" | x16" | x18" | x16" | x14" | | | |
| Model No. | MAB2418/H | MAB2418R/HR | MAB2416/H | MAB2220/H | MAB2220R/HR | MAB2218/H | MAB2218R/HR | MAB2216/H | MAB2018/H | MAB2018R/HR | MAB2016/H | MAB1814/H | MAB1814F/HR |
| Birch Custom Absolute | | | | | | | | | | | | | |
| Diameter | 24" | | | 22" | | | 20" | | | 18" | | | |
| | x18" | x16" | x20" | x18" | x16" | x18" | x16" | x18" | x16" | x14" | | | |
| Model No. | BAB2418/H | BAB2418R/HR | BAB2416/H | BAB2220/H | BAB2220R/HR | BAB2218/H | BAB2218R/HR | BAB2216/H | BAB2018/H | BAB2018R/HR | BAB2016/H | BAB1814/H | BAB1814F/HR |

Recording Custom

For over 30 years, the Recording Custom has set a benchmark for excellence. Possibly the most recorded drum in history, it has enjoyed an unparalleled history of success and innovation. Although trends come and go, the Recording Custom, with its birch shells and pristine interior and exterior finish, delivers a sound that seems “pre-EQ-ed”, perfect for studio or multi-miking in any situation. Unmiked, it will hold its own—with power and tone to spare.



Cherry Wood

Recording Custom

■ Shells BD924Yx2 FT918Y FT916Y TT914Y TT912Y
 ■ Hardware FP9415x2 HS1000 CS840x4 CS845x4 CS945x2 SS840 WS955
 TH904A CH755x3 CH750 CHH920 AC910 DS950 HSAT910

*Cymbals are not included.

All Birch Shells

Recording Custom shells are crafted from select cuts of birch. Floor toms and tom toms are formed with 6-ply designs while bass drums use 7-ply. The series is available in two color finishes, a traditional cherry wood finish and solid black.

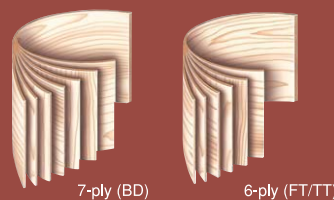

High Tension Lugs

Yamaha's one-piece high-tension lugs are precision-machined to allow severe, high tension tuning.

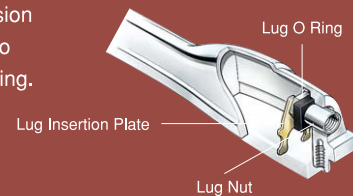

COLOR FINISHES



CW : Cherry Wood

SOB : Solid Black

SET LIST

| Set No. | Individual Package Contents | Bass Drum | Floor Tom | — | — |
|---------|-----------------------------|-------------|-------------|------------|-----------|
| | | Mounted Tom | Mounted Tom | Tom Holder | Tom Clamp |
| RY2F4 | RY2F41 | BD922Y | FT916Y | — | — |
| | RY2F42 | TT912Y | TT913Y | TH945B | — |
| RY2T4 | RY2T41 | BD922Y | TT914Y | — | — |
| | RY2T42 | TT910Y | TT912Y | TH945B | CL945B |
| RY0T4 | RY0T41 | BD920Y | TT914Y | — | — |
| | RY0T42 | TT910Y | TT912Y | TH945B | CL945B |

SPECIFICATIONS

| Standard Size | Diameter | BD | | | | | FT | | | | TT | | | | |
|---------------------|----------|----------|---------|---------|---------|--------|--------|--------|--------|---------|---------|---------|---------|---------|--------|
| | | 26" | 24" | 22" | 20" | 18" | 18" | 16" | 14" | 16" | 15" | 14" | 13" | 12" | 10" |
| x Depth | x14" | x14" | x14" | x14" | x14" | — | — | — | — | x12" | x10" | x9" | x8" | x7 1/2" | — |
| Model No. | *BD926YJ | *BD924YJ | BD922YJ | BD920YJ | BD918YJ | — | — | — | — | TT915YJ | TT914YJ | TT913YJ | TT912YJ | TT910YJ | — |
| x Depth | — | x16" | x16" | x16" | — | x16" | x16" | x14" | x14" | x13" | x12" | x11" | x10" | x9" | x8" |
| Model No. | — | *BD924Y | BD922Y | BD920Y | — | FT918Y | FT916Y | FT914Y | TT916Y | TT915Y | TT914Y | TT913Y | TT912Y | TT910Y | TT908Y |
| No. of Tuning Bolts | 10 | 10 | 10 | 10 | 8 | 8 | 8 | 8 | 8 | 8 | 8 | 6 | 6 | 6 | 5 |

*denotes made-to-order. (Unit: inch)

Recording Custom

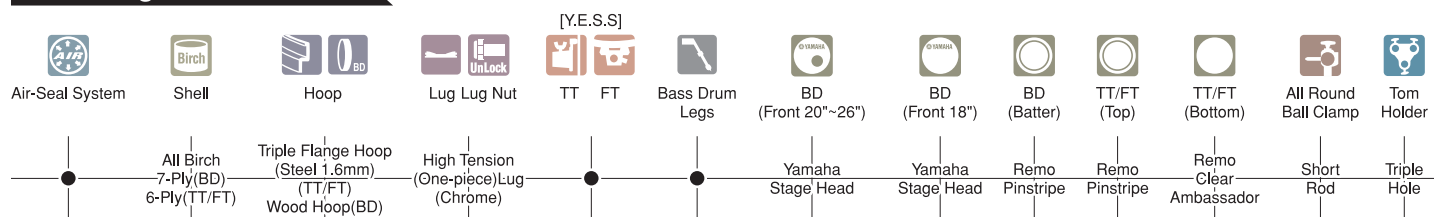

Played Loud, Played Heavy These Drums Respond

OAK CUSTOM

The recent introduction of the Oak Custom by Yamaha sent a shudder through the drum industry. For low end that shakes the floors, crisp highs that penetrate, and mids that ring through the mix, insist on the power of oak.



OAK Custom

■Shells
NBD822UA NFT818A
NFT816A NTF812UA
NTT810UA

■Hardware
FP9315 HS950
SS840 CS845 x3
WS865 DS840

Red Oak

* Snare drum & Cymbals are not included.

Shake It Up With Yamaha Oak

Yamaha is the only drum manufacturer bringing the full potential of oak to a drum kit. From the punchy resonant lows of the bass drum to a snare that bites and toms that cut through, the power of oak definitely shakes things up.

Oak Lugs

Oak custom drums feature newly designed lugs with small footprints and single-bolt attachment that minimize surface contact and maximize shell resonance and sustain. A nylon insert holds tension rods in place under heavy play.

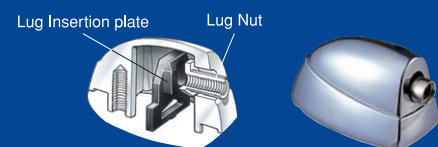

Bass Drum Legs

Holding these powerful drums in place are our Absolute series bass drum legs. Large pipes are Yamaha engineered for greater durability and stability. Spurs slide in and out with a handy knob that also shows spur position at a glance, and a standard drum key locks spurs and height adjustment in place.



OAK Custom NY2FS4A

■Shells
NBD822UA
NFT816A
NTT812UA
NTT810UA
TH945B

■Hardware
FP9315
HS840
SS840
CS845 x2
DS840

* Snare drum & Cymbals are not included.

Musashi Black

COLOR FINISHES

Oak Custom drums are available in four high-gloss finishes. Musashi Black, Red Oak, and York Honey Amber are translucent hues that bring out the distinctive beauty of the wood grain, while Silver Sparkle glitters under lights, epitomizing a vintage look.

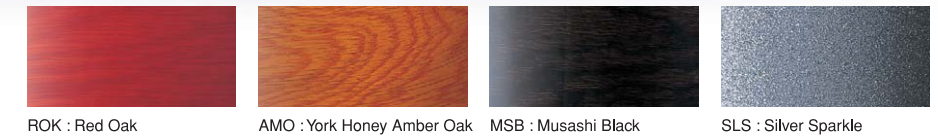

ROK : Red Oak

AMO : York Honey Amber Oak

MSB : Musashi Black

SLS : Silver Sparkle

SET LIST

| Set No. | Individual Package Contents | Bass Drum | Floor Tom | — | — |
|---------|-----------------------------|-------------|-------------|------------|-----------|
| | | Mounted Tom | Mounted Tom | Tom Holder | Tom Clamp |
| NY2FS4A | NY2FS41A | NBD822UA | NFT816A | — | — |
| | NY2FS42A | NTT812UA | NTT810UA | TH945B | — |
| NY2T4A | NY2T41A | NBD822UA | NTT814A | — | — |
| | NY2T42A | NTT812UA | NTT810UA | TH945B | CL945B |
| NY0T4A | NY0T41A | NBD820UA | NTT814A | — | — |
| | NY0T42A | NTT812UA | NTT810UA | TH945B | CL945B |

SPECIFICATIONS

| Diameter | BD | | | | FT | | | | TT | | | | |
|---------------------|-----------------------|-----------------------|-----------------------|-----------|---------|---------|---------|---------|---------|----------|----------|----------|----------|
| | 24" | 22" | 20" | 18" | 18" | 16" | 14" | 16" | 14" | 13" | 12" | 10" | 8" |
| x Depth | x17" | x17" | x17" | x15" | x16" | x16" | x14" | x14" | x12" | x10" | x9" | x8" | x7" |
| Model No. | NBD824UA NBD824UAR | NBD822UA NBD822UAR | NBD820UA NBD820UAR | NBD818UFA | NFT818A | NFT816A | NFT814A | NTT816A | NTT814A | NTT813UA | NTT812UA | NTT810UA | NTT808JA |
| No. of Tuning Bolts | 10 | 10 | 10 | 8 | 8 | 8 | 8 | 8 | 8 | 6 | 6 | 6 | 5 |

* Refer to page 29 for more information on snare drums. (Unit: inch)

Oak Custom

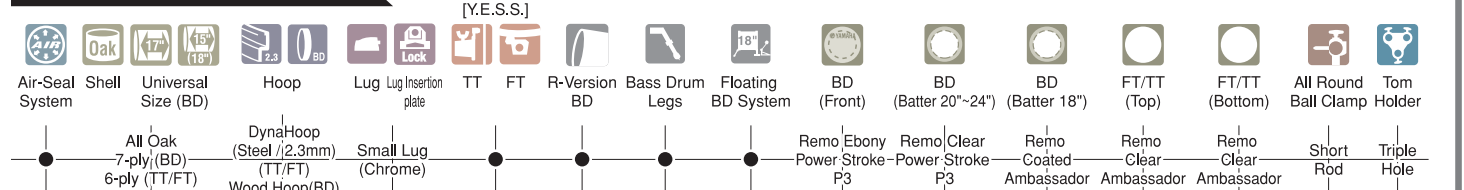

Tour Custom

Maple Shell and Rounder Bearing Edge Deliver Rich Tone with Just the Right Amount of Sustain



Tour Custom

| Shells | Hardware |
|---------|----------|
| TBD822U | DFF9315 |
| TFT818 | HS740A |
| TF1816 | CS845x5 |
| TF1814 | CH755x2 |
| TTT812U | CH750 |
| TTT810U | WS904Ax2 |
| TTT808J | CL945LB |
| TSD0846 | CL945B |
| SD2240 | TH945B |
| | SS840 |
| | DS840 |

Sakura White

All Shells 100% Maple*

All maple shells give the Tour Custom drums its warm, bright tone. Shells are designed with a 60-degree R2 bearing edge that adds the tonal depth found in vintage drums and just the right amount of sustain. Finished with a high gloss lacquer (all new colors) maximizes the sonic potential of the maple shell creating drums that sound and play great in any musical style.

* Bass drum hoops are made of Maple and Philippine Mahogany

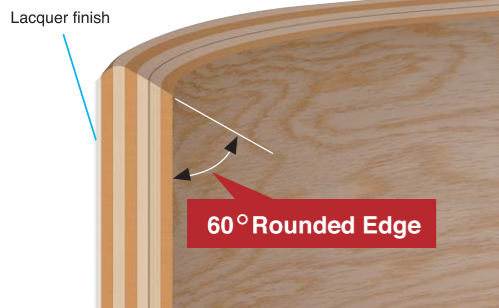

Tour Custom TC2T5

| Shells | Hardware |
|---------|----------|
| TBD822U | CS845x2 |
| TTT810U | WS904 |
| TTT812U | TH945B |
| TTT814 | CL945B |
| TSD0846 | CH755 |
| | CH750 |
| | HS750 |
| | SS740A |
| | DS840 |
| | FP8215 |

Black Onyx

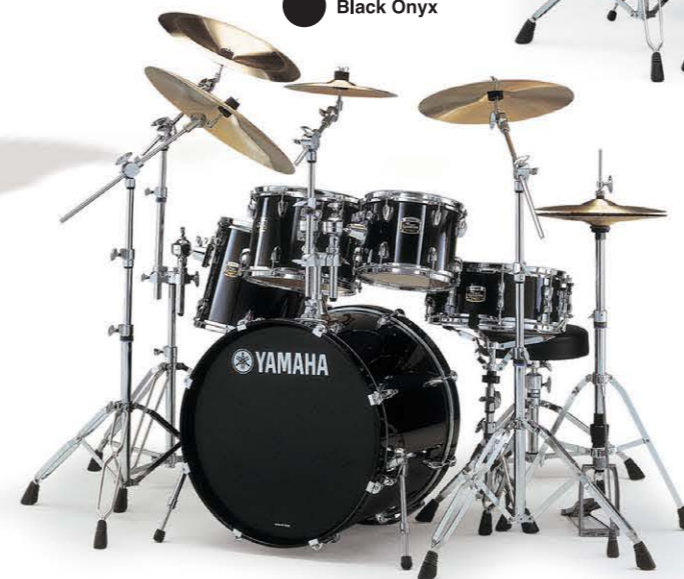

Tour Custom TC2T5

| Shells | Hardware |
|---------|----------|
| TBD822U | CS755x2 |
| TTT810U | TH904A |
| TTT812U | CL945B |
| TTT814 | HS740A |
| TSD0846 | SS840 |
| | DS840 |
| | FP8215 |

Brown Sunburst



Tour Custom TC2FS5

| Shells | Hardware |
|---------|----------|
| TBD822U | HS740A |
| TFT816 | SS840 |
| TTT810U | CS845x2 |
| TTT812U | TH945B |
| TSD0846 | DS840 |
| | FP8215 |

Ocean Blue



COLOR FINISHES



BKO : Black Onyx

OCB : Ocean Blue

SAW : Sakura White

BRS : Brown Sunburst

SET LIST

| Set No. | Individual Package Contents | Bass Drum | Floor Tom | Mounted Tom/Snare Drum | Tom Holder/Tom Clamp |
|---------|-----------------------------|-------------|------------|------------------------|----------------------|
| | | Mounted Tom | Snare Drum | | |
| TC2FS5 | TC2FS51 | TBD822U | TFT816 | TTT810U | TH945B |
| | TC2FS52 | TTT812U | TSD0846 | — | — |
| TC2F4 | TC2F41 | TBD822U | TFT816 | — | CL945LB |
| | TC2F42 | TTT812U | TSD0846 | — | — |
| TC2T5 | TC2T51 | TBD822U | TTT812U | TSD0846 | CL945B |
| | TC2T52 | TTT810U | TTT814 | — | TH945B |

SPECIFICATIONS

| Diameter | BD | | | | FT | | | | TT | | | | |
|---------------------|---------|---------|---------|---------|---------|--------|--------|--------|--------|---------|---------|---------|---------|
| | 24" | 22" | 20" | 18" | 18" | 16" | 14" | 16" | 14" | 13" | 12" | 10" | 8" |
| Standard Size | x Depth | — | — | — | — | — | — | — | — | — | — | — | x7" |
| Model No. | | | | | | | | | | | | | TTT808J |
| Universal Size | x Depth | x17" | x17" | x17" | x15" | — | — | — | — | x10" | x9" | x8" | — |
| Model No. | | TBD824U | TBD822U | TBD820U | TBD818U | — | — | — | — | TTT813U | TTT812U | TTT810U | — |
| Power Size | x Depth | — | — | — | — | x16" | x16" | x14" | x14" | x12" | — | — | — |
| Model No. | | — | — | — | — | TFT818 | TFT816 | TFT814 | TTT816 | TTT814 | — | — | — |
| No. of Tuning Bolts | | 8 | 8 | 8 | 6 | 8 | 8 | 6 | 8 | 6 | 6 | 6 | 5 |

Tour Custom

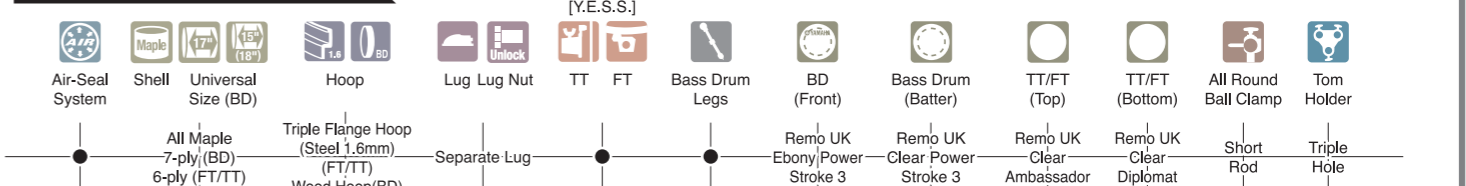

STAGE CUSTOM

All Birch Shell

100% Birch Shell Stage Custom has evolved again

As with the introduction of Stage Custom in 1995 YAMAHA once again sets the standards of value and sound. By borrowing from our legendary Recording Custom drums, we are proud to introduce new 100% Birch Shell Stage Custom.



● Raven Black

STAGE Custom

| Shells | Hardware |
|--|-------------------------------|
| BBD624U BFT616 BTT613U BTT608J BSD1050 | TH945B HS740A CSAT924A WS955 |
| BBD620U BFT614 BTT612U SD266A | CS755X4 SS740A CL945BX2 WS904 |
| BFT618 BTT616 BTT610U BSD1250 | CH750 FP9415X2 CH755 CL940LB |



STAGE Custom SCB2FS5

| Shells | Hardware |
|----------------|-----------------|
| BBD622U TT612U | TH945B SS740A |
| BFT616 BSD0655 | CS755X2 FP7210A |
| BTT610U | HS740A |

● Raspberry Metallic



STAGE Custom SCB0F5

| Shells | Hardware |
|----------------|-----------------|
| BBD620U TT612U | TH945B SS740A |
| BFT614 BSD0655 | CS755X2 FP7210A |
| BTT610U | HS740A |

● Natural Wood

COLOR FINISHES (Brilliant, durable all-lacquer finish)

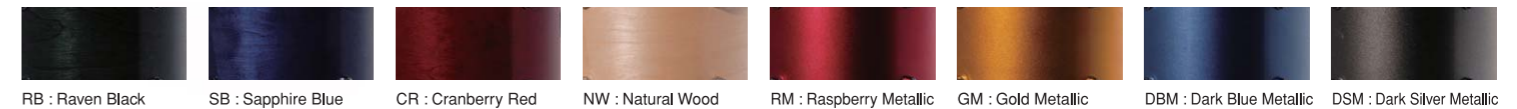

SET LIST

| Set No. | Bass Drum | Floor Tom | Tom Tom | Tom Holder/Tom Clamp | Snare Drum |
|----------|-----------|-----------|---------|----------------------|------------|
| SCB4F41 | BBD624U | BFT616 | — | CL945LB | SD266A |
| SCB2FS51 | BBD622U | BFT616 | BTT610U | TH945B | BSD0655 |
| SCB0F51 | BBD620U | BFT614 | BTT610U | TH945B | BSD0655 |

| Set No. | Mounted Tom | Cymbal Stand | Hi-Hat Stand | Snare Stand | Foot Pedal |
|---------|-------------|--------------|--------------|-------------|------------|
| SCB12HW | BTT612U | CS755x2 | HS740A | SS740A | FP7210A |

*A set consist of 1xShell Box +1xHW+12"Tom Box

SPECIFICATIONS

| Universal Size | x Depth | BD | | | | FT | | | TT | | | | |
|---------------------|---------|-----------|-----------|-----------|-----------|-----------|-----------|-----------|-----------|-----------|-----------|-----------|---------|
| | | Model No. | Model No. | Model No. | Model No. | Model No. | Model No. | Model No. | Model No. | Model No. | Model No. | Model No. | |
| | x17" | x17" | x17" | x15" | x16" | x14" | x14" | x12" | x10" | x9" | x8" | x7" | |
| | BBD624U | BBD622U | BBD620U | BBD618U | BFT618 | BFT616 | BFT614 | BTT616 | BTT614 | BTT613U | BTT612U | BTT610U | BTT608J |
| No. of Tuning Bolts | 8 | 8 | 8 | 6 | 8 | 8 | 6 | 8 | 6 | 6 | 6 | 6 | 5 |

100% BIRCH

ALL BIRCH 6PLY

Shell

The shell is a key factor in a drum's ability to "rumble," or resonate. Accordingly, the Stage Custom employs 100% birch - a classic in the realm of high-class drum kits. Moreover, with its six-ply structure the Stage Custom accurately conveys the vibrations produced at the impact surface, achieving performance that overwhelms anything in its class.

Hardware

- 1 Boom Cymbal Stands adopt a new boom tilter design for improved stability and adjustability.
- 2 A center tilter that can be set for highly accurate cymbal positioning and player articulation.
- 3 The YESS specification floor-tom bracket, incorporating a wing bolt.
- 4 Improved snare basket adjustment mechanism.

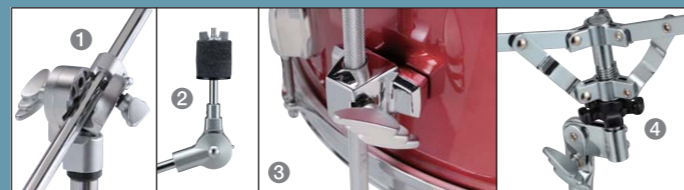

Stage Custom

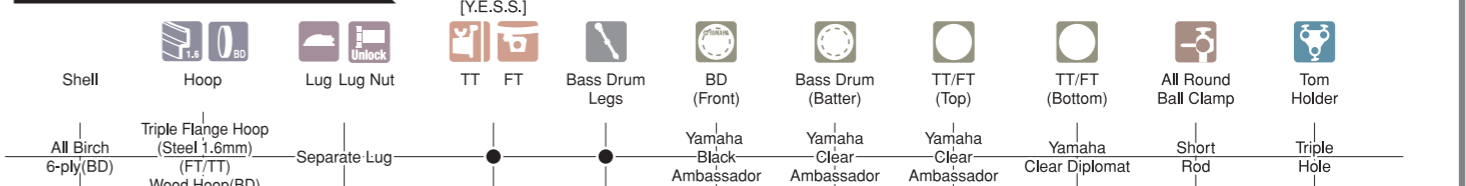

Yamaha SYSTEM DRUMS... SIGNATURE

Hipgig / Hipgig Sr. / Junior Kit
Club Jordan / Subkick / Wedges / DAXDAD

Rick Marotta Signature Hipgig

An original idea from Rick Marotta results in the unique Hipgig compact drum kit.

Compact Basic Drum Kit

Toms, snare, cymbals (crash, ride) all attach to the bass drum. In addition to the 13- and 10-inch toms, compact 12- and 8-inch tom toms are optionally available to provide a wider variation in sound.



Shells

Hipgig shells, composed of 7-ply birch and Philippine mahogany, deliver a penetrating, funky sound that belies their diminutive size.

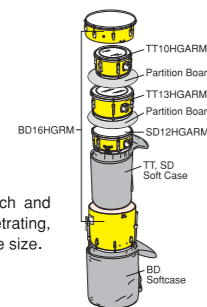

Hipgig Set

- HG6T41ARM Shells
- BD16HGARM
- TT13HGARM
- TT10HGARM
- SD12HGARM
- BD Softcasex1
- TT, SD Softcasex1

*This model is sold as a set only. Individual components are not sold separately.
*Cymbals are not included.

- Hardware (Recommended)
- DS750
- HS650A
- TH904A
- CL940B
- CL940LBx2
- CH755x2
- FF7210A
- PPC4A

COLOR FINISHES

CW : Cherry Wood

MY : Mellow Yellow

WMP : White Marine Pearl

Cherry Wood

■TT08HGARM
Size : 8" x 5 1/2"

■TT12HGARM
Size : 12" x 6 1/2"

■SPECIFICATIONS

| | BD (Separate type) | TT | SD |
|-------------------------|-----------------------------------|--|------------------------|
| Shells | Birch & Philippine Mahogany 7-ply | | |
| Size (Diameter x Depth) | 16"x20" | 13"x7" | 12"x5" |
| Tuning Bolts | 8 | 6 | 6 |
| Hoops | Triple flange (steel / 1.6mm) | | |
| Head | Top | Remo Renaissance Power Stroke 3 (Batter) | Remo Ambassador Coated |
| | Bottom | Remo Renaissance Power Stroke 3 (Front) | Remo Clear Ambassador |

Optional 8" and 12" tom toms

| | TT08HGARM | TT12HGARM |
|-------------------------|-----------------------------------|-----------------------|
| Shells | Birch & Philippine Mahogany 7-ply | |
| Size (Diameter x Depth) | 8" x 5 1/2" | 12" x 6 1/2" |
| Tuning Bolts | 5 | 6 |
| Hoops | Triple flange (steel / 1.6mm) | |
| Head | Top | Remo Pinstripe |
| | Bottom | Remo Clear Ambassador |

* Soft case supplied. The tom will not fit inside the bass drum.



Rick Marotta

"In all the years I've been with Yamaha, I have never put my name on any one product, because I could never make up my mind. I could not, however, resist the Hipgig kit. It is one of the great drum innovations by Yamaha. I have been using it live and in the studio for all types of music."

Al Foster Signature Hipgig Sr.

Hipgig Sr.—an upgraded version of the Hipgig—endorsed by Yamaha veteran drummer Al Foster

Larger Diameter Shells Offer Greater Performance Possibilities

Compared to the original Hipgig, the Hipgig Sr. offers larger drum sizes for more volume and versatility, while maintaining compactness and portability. The bass drum has gone from its original 16" diameter to 18", while the mounted toms have increased to 12" and 14". Similarly, the snare has increased to 13". Shells are 7-ply and constructed using our Air Seal System. Yamaha CS-651 cymbal stands permit use of larger cymbals and afford greater variation in set up.

Compact Packing

Two toms and the snare all fit neatly into the two-piece bass drum which then fits into its own soft case for easy transport. Hardware and the bass drum stool all fit neatly into a special hardware bag.



"The Hipgig Sr. is built for the professional, sounds amazing, and is quick to pack up. I'm proud to have my name on it!"

Al Foster

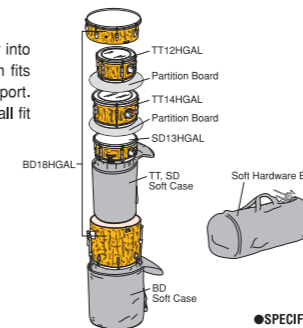

Hipgig Sr. Set (2 packages)

- HG8T46AL
18"x22" BD, 12"x 6 1/2" tom, 14"x 8 1/2" tom, 13"x 5" SD, CL-940LB (3), CS-651 (2), HS-650A, FP-6210, DS-750, and soft gig bags for drums and hardware
- TT-10HGAL
10"x 6 1/2" tom for Al Foster Hipgig Sr., includes gig bag

* Cymbals are not included.
* This model is sold as a set only. Individual components are not sold separately.
* Cymbal and hi-hat stands shown in the photo are a previous model type however, new types are used with the current model.

Jaguar Pattern



■TT10HGAL
size : 10" x 6 1/2"
* Soft case supplied.
The tom will not fit inside the bass drum.

COLOR FINISHES

JGR : Jaguar Pattern
WMP : White Marine Pearl
GMP : Gold Marine Pearl

■SPECIFICATIONS

| | BD (Separate type) | TT | SD | Optional 10" tom tom |
|-------------------------|-----------------------------------|--|------------------------|------------------------|
| Shells | Birch & Philippine Mahogany 7-ply | | | |
| Size (Diameter x Depth) | 18"x22" | 14"x8 1/2" | 12"x6 1/2" | 10" x 6 1/2" |
| Tuning Bolts | 8 | 8 | 6 | 6 |
| Hoops | Triple flange (steel / 1.6mm) | | | |
| Head | Top | Remo Renaissance Power Stroke 3 (Batter) | Remo Ambassador Coated | Remo Ambassador Coated |
| | Bottom | Remo Renaissance Power Stroke 3 (Front) | Remo Clear Ambassador | Remo Ambassador Snare |

Manu Katché Signature Junior Kit

A request by Manu Katché results in a great compact kit for kids

Compact Drum Kit Delivers Real Drum Tone

"Why don't you make a real drum kit for kids?"

That request by Manu Katché caught the ears of our designers and soon had them busy designing this unique kit. For small players it is designed compact, but it is far from being a toy. The 16" x 16" 9-ply bass drum with a 6-ply 13" x 12" floor tom, 10" x 7" tom, and 12" x 5" snare are all made of quality Philippine mahogany using our original Air Seal System. These drums deliver solid tone that is unbelievably real.

Floating Bass Drum System

Yamaha's floating bass drum system utilizes a pipe post stabilizer that provides height adjustment on the pedal side of the bass drum to ensure that the beater makes contact with the center of the head.

Lacquer Finish

The Jr. Kit features a lacquer finish on Philippine Mahogany shells which offers a more open sound compared to covering finishes.



Hardware

The kit comes fully equipped with lightweight hardware that is durable and easy to use.

"True power is not always revealed visually."

Manu Katché



Junior Kit (2 packages)

- JK6F46MK
BD16AJKMK
FT13AJKMK
TT10AJKMK
SD12AJKMK
CL940LB
- JK6F42DMK
CS651Ax2
SS662
HS650A
FP6110A
DS550U

* Cymbals are not included.
* This model is sold as a set only. Individual components are not sold separately.

Silver

COLOR FINISHES

SL : Silver
BK : Black
PL : Purple

■SPECIFICATIONS

| | BD | FT | TT | SD |
|-------------------------|-------------------------------|---------------------------------------|----------------|----------------|
| Shells | Philippine Mahogany 9-ply | Philippine Mahogany 6-ply | | |
| Size (Diameter x Depth) | 16"x16" | 13"x12" | 10"x7" | 12"x5" |
| Tuning Bolts | 8 | 6 | 6 | 6 |
| Hoops | Triple flange (steel / 1.6mm) | | | |
| Head | Top | Remo UK Clear Power Stroke 3 (Batter) | Remo UK Coated | Remo UK Coated |
| | Bottom | Remo UK Ebony Power Stroke 3 (Front) | Remo UK Clear | Remo UK Snare |

Low-frequency capture device

Subkick

The Subkick consists of a 10" x 5" birch/Philippine mahogany 7-ply shell housing a 16 cm, 50-watt low-frequency driver cone. The "reversed speaker" acts as a large diaphragm microphone and enables the Subkick to faithfully capture extremely low frequencies produced by bass drums. It can be used in tandem with a standard kick mic' set up to deliver a monstrous bass drum sound. The Subkick also works effectively with floor toms, bass guitars, low brass, etc.



SKRM100



●SPECIFICATIONS

| SKRM100 | |
|---------------------|--|
| Size | 10"x5" |
| Shell | Birch & Philippine Mahogany 7-ply (w/ Rod Clamp) |
| Color Finish | Vintage Black |
| Hoop | Triple Flange (Steel / 1.6mm) |
| Tuning Bolts | One-piece Lug (6) |
| Head (Top & Bottom) | Mesh Head |
| Type | Dynamic |
| Polar Pattern | Bi-directional |
| Output Jack | XLR-3-32 (cannon) jack |
| Weight | Main unit : 4kg, Stand : 3kg |
| Frequency Response | 50Hz-2000Hz |
| Output Impedance | 9Ω |
| Front Sensitivity | -47dB/μ Bar (1kHz) |

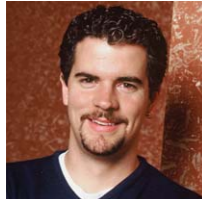

Positioning Produces a Wide Range of Tonal Variations

Varying placement and proximity of the Subkick affects the nature of the sound captured, opening the door to a wide range of tonal possibilities. Try it directly in front of the sound hole or from various distances in front of the head to "dial in" degrees of ambience, punch, and volume. The Subkick works equally well in the studio and live.

Specially Designed Stand Offers Versatile Placement

The three-legged stand and ball clamp offer excellent stability and durability while the ball clamp offers versatile placement and angle adjustment of the mic unit.

Russ Miller Signature Wedges



L.A. session player, Russ Miller, was looking for a way to produce a cross stick sound from 12- and 13-inch snares when he came up with the idea for the Groove-Wedge. It attaches to the tuning bolts on most drums fitted with standard metal rims. The Groove-Wedge is designed for cross stick and rim shots while the Cascara-Wedge, which attaches in the same manner, functions as a percussion board.

Groove-Wedge RMGW



The all maple 19-ply Groove-Wedge easily attaches to most 8- to 15-inch drums fitted with standard metal rims. In addition to great rim shots it offers a wide variety of sonic possibilities.

Jingle-Wedge RMJW



The Jingle-Wedge fits on most 10- to 15-inch drums* to add the timbre of a tambourine to the beat. It layers well with the sound of other drums and is also great for creating classic R&B backbeats when layered with the snare.

*Excluding the YD Stage Custom Series 14-inch 6-hole drum.

Cascara-Wedge RMCW



The dancing Cuban cascara rhythm is usually played on the side of the floor tom. The cascara wedge fits most 10- to 18-inch drums. The 7-ply construction gives an authentic cascara tone while protecting drum shells from abrasion.

Club Jordan

Club Cocktail Drum System



"Stand up and free yourself!"



Club Cocktail Drum System

■CD-15CJ
CJ cocktail drum, 15" x 24", 8 lugs, includes reverse foot pedal w/attachment, cymbal arm (accommodates cowbell, woodblock, closed hi-hats, and a cymbal), and percussion board

■FP-810CD
Cocktail drum reverse foot pedal

■FP-B
Cocktail drum reverse foot pedal bracket assembly

■CD-BOARD
CJ percussion board, 7-ply natural birch shell, includes brackets (fits 14", 15", and 16" 8-lug toms)

●COLOR FINISHES



SLS : Silver Sparkle

PKS : Pink Sparkle



■CDSET

CD-15CJ, SD-08CJ, TT-10CJ

* Cymbals and Cowbell are not included.



■TT-10CJ

CJ tom, 10" x 5", 6 lugs, includes L-arm mounting, YESS mounting bracket (mounts directly to main drum)



■SD-08CJ

CJ snare drum, 8" x 5", 5 lugs, includes L-arm, YESS mounting bracket (mounts directly to main drum)

Yamaha SYSTEM DRUMS... SIGNATURE

Unique Bass Drum

DAXDAD



BD12DD

* Foot Pedal are not included.

*A soft case that makes transport easy is also included.
*Foot pedal not included.

A Unique Drum, A Unique Sound

It looks like a stretched out tom, but the DAXDAD is a powerful sub bass drum that produces a variety of tones. The 12"x22" 7-ply birch/Philippine mahogany shell, formed with our Air Seal System, produces a focused, punchy sound with good sustain. By altering respective tensions of batter and front heads, a wide range of tonal variations can be achieved. The DAXDAD is perfect for primary or secondary bass drum.

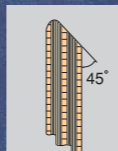

Birch & Philippine Mahogany 7-ply

Floating Bass Drum System Offers Stability

The Yamaha floating bass drum system employs a pipe post stabilizer, which provides height adjustment and enables the beater to strike dead center of the head. A memory clamp ensures quick, precise set up. The system is stable, even under heavy playing.



Four Air Holes

Four air holes allow air to escape, reducing air column backlash on the batter head, thus promoting player and pedal comfort.



●SPECIFICATIONS

| BD12DD | |
|--------------|---|
| Size | 12"x22" |
| Shell | Birch & Philippine Mahogany 7-ply |
| Color Finish | Vintage Natural |
| Hoop | Triple Flange (Steel / 1.6mm) |
| Lug | Separate Lug |
| Tuning Bolts | 6 |
| Head | Front: Remo Pinstripe Batter: Remo Pinstripe |



Philosophy of the Yamaha Snare Drums



Wood Shells

The sound of any drum starts with the shell. The creation of all Yamaha shells starts with the selection of the finest materials possible. Excellent woods are carefully selected and cut into plies and sealed together precisely with evenly distributed air pressure using our Air-Seal System. As a result every shell created with this process is in round and of uniform thickness to an incredibly perfect degree, and produces superior tone quality with exceptional durability.



Metal Shells

Every Yamaha snare drum is in round and has a finely honed edge and carefully shaped snare bed. Steel shells are 1.2mm thick; brass and copper shells are 1.5mm thick; and aluminum shells are set at 2.0mm. Brass shells deliver a rich, colorful tone with well-balanced definition through the dynamic range. Some say that brass lies between steel and wood in timbre. Versatile enough for concert settings, copper shell snare drums are characterized by sharp attack and strong low frequency response. Steel shell snare drums exhibit strong attack, a bright tone, and long and sustaining rim-shots. Aluminum shells offer a light, clean, and dry tone with plenty of body.

Bearing Edge

In 40 years of product development, Yamaha has found four wood snare drum bearing edge designs that produce unique tonal character and depth. Sharp edges deliver sharper tone with excellent response and rounded angles produce a rounder, thicker tone. Varying the thickness of the radius top allows for further modification. Using different bearing designs on the top and bottom of the snare is also effective in modifying the tone.

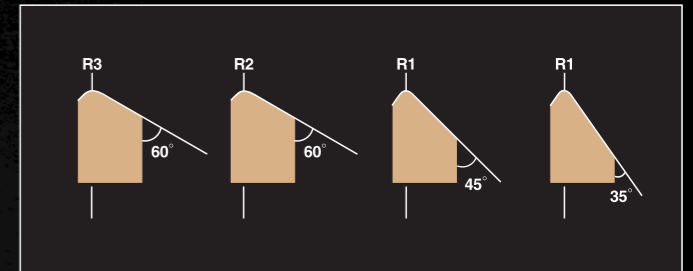

Snare Bed

Snare bed depth greatly influences snare effectiveness making it the most important factor in creating the snare drum sound. Yamaha offers three snare bed types; a standard 1.8mm, a 2.7mm that offers greater snare sensitivity, and the 3.5mm used on the Steve Gadd Signature Snare Drum.

- Standard 1.8mm
- For Sensitive Sound 2.7mm
- For Staccato Sound 3.5mm

Vent Holes

The number of vent holes in the shell has an impact on projection. The number of vent holes found in Yamaha snare drums will vary according to the type of tone being sought.

While the single hole is standard, a two-hole design like that used on the Sensitive Series, offers greater response, and the nine-hole design on the Loud Series delivers a crisp sound.

Sonic Hoop

"Sonic Hoop Reinforcement Concept"

In the past, reinforcement hoops were used to compensate for inadequacies inherent to old shell designs that would often cause the shell go out of round. Utilizing Yamaha's Air Seal System, it is virtually impossible for shells to go out of round. Our reasoning for using reinforcement hoops now is strictly a musical one. We utilize these hoops to bring out particular tonal characteristics, giving the drummer new and specific musical choices.

When a shell is being created via our Air Seal System, the Yamaha "Sonic Hoops" are being treated at the same time. In the end, this original process causes the hoops and shell to act as one unit as opposed to merely two pieces being glued together. This guarantees a sturdy reinforcement. Musically, it also produces a short sustain of the fundamental note, while also giving a rich and longer overtone.

Sonic Hoops can be found on the V-Series(VSD), Steve Jordan, and Andre Ceccarelli models.

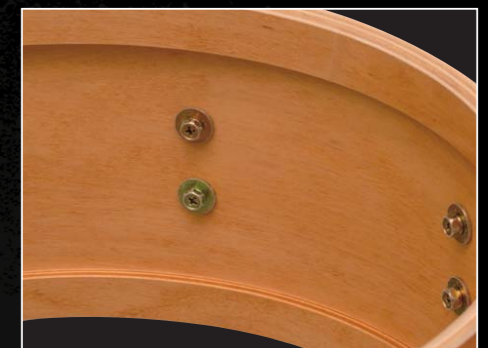

Wood Hoops

Our 19-ply vintage wood hoops are crafted from select maple, specially coated with urethane for maximum durability. Wood hoops promote an organic sound characterized by good sustain. Rim-shots gain solidity and power simply not found with other hoops.

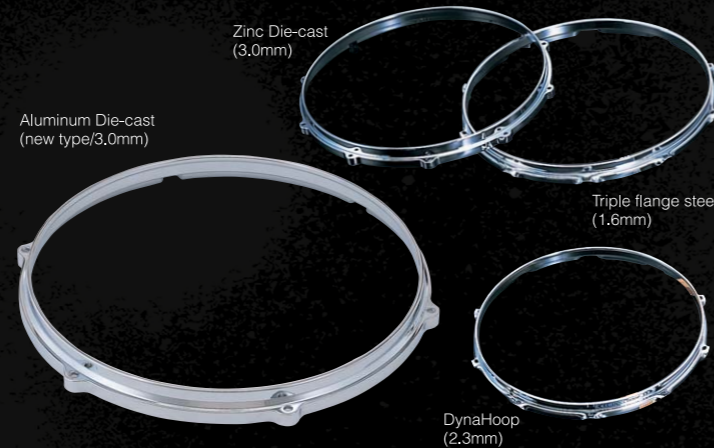

Metal Hoops

The design and composition of the hoop play an important role in the sound of the snare drum, especially when executing rim-shots. Yamaha employs three types of metal hoops (steel, aluminum, and zinc) and two different manufacturing processes (roll forming and die-cast) in the production of four different hoop styles (see characteristics chart below). The standard 1.6mm steel hoop can be used in all situations for a wide-open sound. The 2.3mm Dyna Hoop offers a sharper response and more solid rim-shots. Our 3.0mm zinc die-cast hoop firmly anchors the drumhead and delivers penetrating, full-bodied rim-shots. The 3.0mm Aluminum Die-Cast hoop provides many of the attributes of the Zinc hoop but without the extra-weight. Rim-shots are slightly more open, while attack and decay are magnified. Aluminum Die-Cast and Zinc Die-Cast hoops fix the head securely on the bearing edge. This precise head seating promotes natural tone and minimizes sound loss.

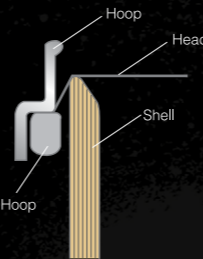

Wood Hoop Waves

The power spectrum decreases smoothly from low frequency to high frequency ranges. Harmonic sounds are rich in middle frequency range (300-600Hz).



Die-cast Hoops Waves

The power spectrum is low in middle frequency range and harmonic sounds in high frequency range (600-2,000Hz) is outstanding.

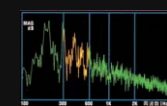

| Model | Triple flange Hoop | DynaHoop | Aluminum Die-cast Hoop | Zinc Die-cast Hoop | Wood Hoop |
|-------------------------|--------------------|----------|--|---------------------------|---|
| Shape | | | | | |
| Material | Steel | | Aluminum | Zinc | Maple Wood |
| Thickness | 1.6mm | 2.3mm | 3.0mm | 3.0mm | (19-ply) |
| Method of manufacturing | Roll Forming | | Die-cast | | Air Seal |
| Feature | Standard Hoop type | | Extraordinary attack and decay creates a strong, tight sound | | Fat, round sound, Rim shots are powerful and explosive. |
| | | | Crisp rim shots. | Crisp and deep rim shots. | |

Snare Drums

Strainers

Yamaha strainers have undergone many design refinements. Today they are industry standards in terms of ergonomics, effectiveness, and quiet use. Fine snare adjustments are made with a central knob that allows small tension increments. Other adjustments are made with a drum key.

Two-piece snare holding plate

Snare strings looped around the two plates are held securely in place and out of the way. (The two-piece snare holding plate is not employed on detachable strainer system.)

Drum Key Tightening

A drum key secures snare strings to plates for quick operation and to ensure non-slip snare performance.

Holding Plate Position

H type strainers are positioned closer to the shell to provide greater lifting power for superior snare to head contact.

B type (butt end) strainers also minimize strainer to shell contact.

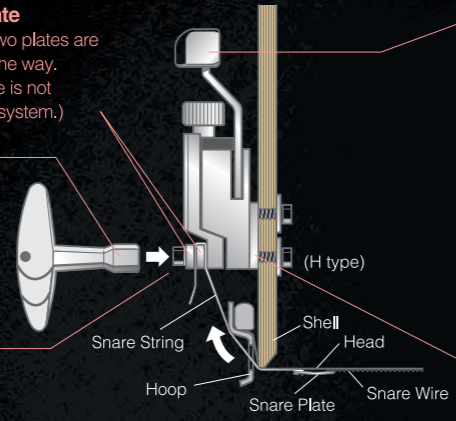

Smooth Lever Operation

All Yamaha strainer levers are designed for ease of grip and liquid smooth operation. At rest, they lock reliably. G and H lever types are particularly smooth and feature finger fitting contoured levers.

Silicon Rubber

P and B type levers utilize a silicon rubber on the lock and lever parts for secure locking with quiet operation.

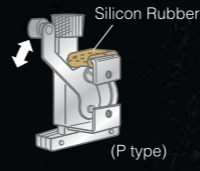

Minimum Contact

Yamaha strainers are designed to contact the shell minimally, as are our butt plates, ensuring full shell vibration.

Detachable Strainer: New Strainer on Brass, Copper, and Aluminum Shells

Our new strainer design, on both lever and butt plate, allows quick and easy removal of the snare assembly-plate, strings, and snares detach as a single unit. This facilitates quick head change without having to reassemble the entire snare system. You can even attach a spare snare, perhaps one of different timbre, to the plates and perform a quick change between songs! (On 4" deep snare drums, detachable strainers are employed on the release side)

Detachable Snare System (Pat. Pend.)

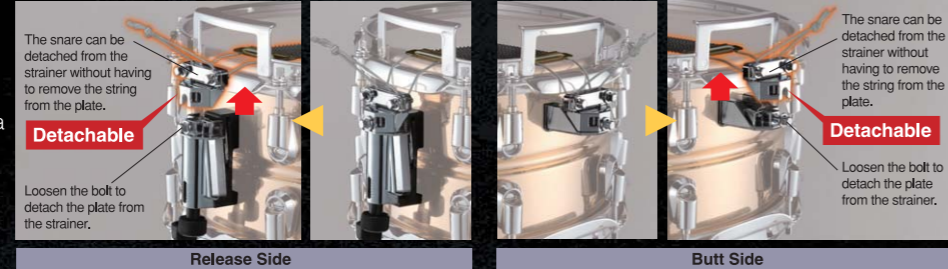

Nouveau Lugs on Brass and Copper Shells

Nouveau Lugs utilize a floating design that eliminates contact between the lug casing and shell by hitching the lugs to bolts at the shell side so the shell can resonate freely. Their quick release design also provides for very quick head changes and reduces the risk of losing washers since it is no longer necessary to entirely remove the tuning bolt

Designed to Deliver Greater Power

New Brass and Copper shells (1.5mm thick) are designed thicker than previous models (1.2mm thick) to deliver a more powerful tone.

Brass, Steel Shell Lineup Includes Small Diameter Snares

Brass and shells are both available in smaller diameter 13-inch configurations. The steel lineup also includes two 12-inch configurations and a 10-inch model. The 12-inch and 10-inch diameter shells are fitted with rod clamps so you can attach the snare drum to a tom stand and use it as an effect snare.

"Detachable Strainer" Brass, Copper, and Aluminum Shells

(Detachable Strainers are also employed on the release side of four-inch deep steel models)

YAMAHA SNARE DRUMS LINEUP

| Shell | WOOD | | | | | | | | | METAL | | | |
|--------|---------------|---------------|-----------------------|-------------|-----------------------|--------------|---------------|------------|-------------|--------|----------|--------|--------|
| | Maple | | | | Birch | | OAK | | | Steel | Aluminum | Brass | Copper |
| Series | V-Series(VSD) | S-Series(MSD) | MAPLE CUSTOM ABSOLUTE | TOUR CUSTOM | BIRCH CUSTOM ABSOLUTE | STAGE CUSTOM | L Series(NSD) | OAK CUSTOM | MUSASHI | | | | |
| 14" | 7" | — | — | MAS1470 | — | BAS1470 | — | NSD1470 | — | — | SD4470 | — | — |
| | 6 1/2" | — | MSD1465 | — | — | — | — | — | — | SD2465 | — | SD6465 | SD3465 |
| | 6" | VSD1460 | — | MAS1460(H) | TSD0846 | BAS1460(H) | — | — | — | — | — | — | — |
| | 5 1/2" | — | MSD1455 | — | — | — | BSD0655 | NSD1455 | NSD085A | — | SD2455 | SD4455 | SD6455 |
| 13" | 4" | — | — | MAS1440 | — | — | — | — | — | — | SD4440 | SD6440 | — |
| | 6 1/2" | — | MSD1365 | — | — | — | — | — | NSD1365M | — | SD4365 | — | — |
| | 5 1/2" | — | — | — | — | — | — | — | — | SD2355 | SD4355 | — | — |
| 12" | 4" | — | — | — | — | — | — | — | — | SD2340 | SD4340 | — | — |
| | 6" | — | — | — | — | — | — | — | NSD1260MBGW | — | — | — | — |
| | 5 1/2" | — | — | — | — | — | — | — | — | SD2255 | — | — | — |
| 10" | 5" | — | — | — | — | — | — | — | — | — | — | — | — |
| | 4" | — | — | — | — | — | — | — | — | SD2240 | — | — | — |
| | 5 1/2" | — | — | — | — | — | — | — | — | SD2055 | — | — | — |
| 8" | 5" | — | — | — | — | BSD1050 | — | — | — | — | — | — | — |
| | 4 3/4" | — | — | — | — | — | — | — | NSD1047M | — | — | — | — |

Lugs

Our lugs incorporate special lug receiving units, not springs, for seating tuning rods securely. Nouveau Lugs on our Brass and Copper series snare employ a floating design that eliminates contact between lug casing and shell. The lug casing hitches only to a fixed shell bolt and can be snapped off for quick head changes. Our other more conventional lug casing are small in size, minimizing lug-to-shell contact, and incorporating nylon inserts that prevent tuning rods from loosening under heavy rim-shots. Our high-tension one-piece lugs can accommodate heads tensioned to the limit.

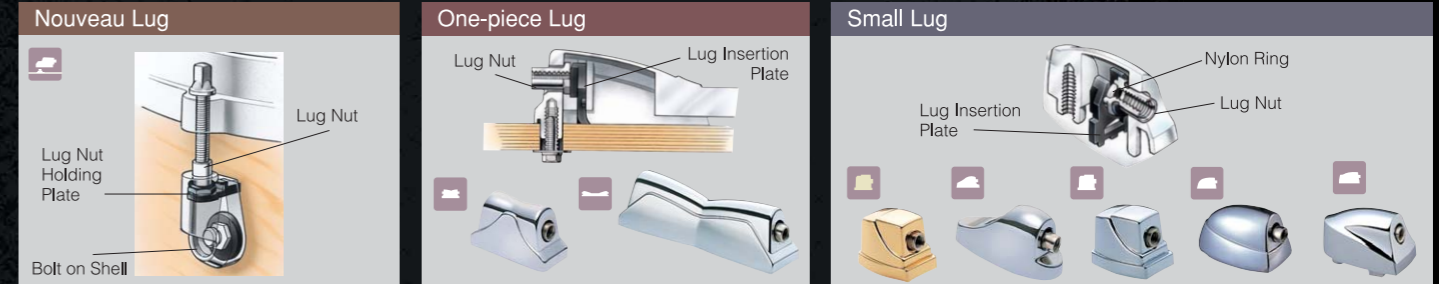

Snare

Yamaha snare drums utilize two different basic snare types, stainless steel and hi-carbon steel, each possessing unique sonic characteristics. Strong nylon strings or woven filament tapes attach snare stands securely to strainer and butt plates.

Snare Plate (Pat. Pend.)

Yamaha snare plates offer superior snare to head contact due to the slight bend in their design. When the string is drawn tight, the edge of the patented snare plate is pulled upward putting the snare in full contact with the head. Snare plates in the CP series are made using a special bonding agent between the plate and the coil that provides greater durability and finer response compared to previous designs. Snare coils on CP series snare drums are now covered with a special new finish that allows more of the material's tone to come through.



Strong Snare Strings

Nylon strings are covered with a nylon braid for maximum strength and durability.

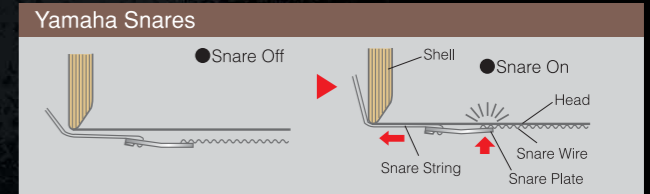
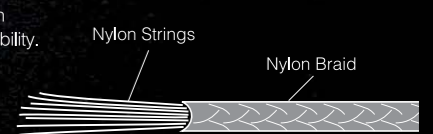

| Side | Release Side | | | | | | Butt Side | | | |
|-------|------------------------------|--------|--------|---------|--------|--------|-----------|--------|---------|--------|
| | B type | H type | I type | IP type | P type | B type | DC type | G type | IP type | P type |
| Model | | | | | | | | | | |
| Shape | B-5 type, B-6 type, B-8 type | | | | | | | | | |

SIGNATURE MODEL

| Shell | WOOD | | | | METAL | | | |
|-------|--------|---------------------------|--------------------------|----------------------|--------------------|--------------------------|----------------------|----------------------|
| | Maple | Birch | Beech | Birch & P.Mahogany | Steel | Brass | Copper | |
| 14" | 7" | MSD1470EJ (E. Jones) | — | — | — | — | — | |
| | 6 1/2" | — | BSD1465NJR (J. Robinson) | — | — | SD465AMK (M. Katché) | SD6465MB (M. Bordin) | |
| | 6" | MSD14AF (A. Fig) | — | — | — | — | — | |
| | 5 1/2" | ASD1460BC (B. Cobham) | — | — | — | SD255ASG (S. Gadd) | SD455AMK (M. Katché) | SD655ARH (R. Haynes) |
| | 5" | MSD1455AC (A. Ceccarelli) | — | WSD1455SE (S. Emory) | — | SD2455JC (J. Chamberlin) | SD455APL (P. Leim) | — |
| 13" | 4" | — | — | — | — | SD255ANC (N. Chandler) | — | |
| | 5" | MSD14ASG (S. Gadd) | BSD14ASG (S. Gadd) | — | — | — | — | |
| | 3 1/2" | — | — | — | — | SD435ADG (D. Garibaldi) | — | |
| 10" | 7" | — | — | WSD13AJ (A. Jimbo) | — | — | — | |
| | 6 1/2" | MSD1365SJ (S. Jordan) | — | — | — | — | — | |
| 8" | 5 1/2" | MSD13ADW (D. Weckl) | — | — | — | — | — | |
| | 4" | — | — | — | SD08CJ (S. Jordan) | — | — | |

New Concept Series Snare

V-Series

“Vintage” Concept

The thin 4-ply shells are fitted with 6-ply reinforcement rings. The shell delivers a warm, open sound with short sustain that is in keeping with the “vintage” concept.

Sonic Hoop Reinforcements

The shells are 4-ply designs fitted with 6-ply reinforcement rings. Sonic hoops are formed, like the shell, using our exclusive Air-Seal System. Fitting perfectly into the shell's interior they deliver greater reinforcement and a sound rich in overtones with a fat, short sustain.



Hoops

To obtain a rich vintage sound we chose a triple-flange hoop with 8 tensioners for the 14-inch shell. The lower tension delivers a deeper, more open sound.



■ VSD1460 Size:14"x6"

Vintage Coating

In order to best demonstrate the characteristics of the shell materials, special synthetic resin coating materials are carefully applied by hand. This thin but hard coating provides durability and stubborn resistance to changes in temperature and humidity. At the same time, it has a minimal effect on shell vibration, so the each drum produces all the power and nuance you put into it. Another special feature of your Vintage Coated* YAMAHA drums is that they'll gradually become richer and deeper in color over time.

*The color change is a characteristic of this special coating material. Two new colors are also available, as well as the conventional colors: Vintage Natural and Vintage Black.

COLOR FINISHES



S-Series

“Sensitive” Concept

Bright, warm tone is characteristic of the maple shell. The snare delivers excellent response with superior attack.

Highly Respected Maple Custom

Yamaha's signature series, the Maple Custom. Highly popular with drummers around the globe, our Maple Custom series welcomes this new addition that brings new life to the lineup.

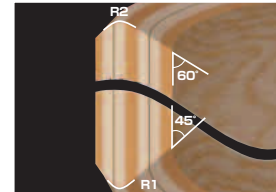

Bearing Edges

Different shaped bearing edges are used on the top and bottom of the shell. The batter side bearing edge has a gentle R2 edge with a 60° slope that gives the drum a milder mid to low-end tone. A sharper R1 edge with a 45° slope on the snare side blends in a sharp, clear response.



■ MSD1455 Size:14"x5 1/2"

■ MSD1465 Size:14"x6 1/2"

■ MSD1365 Size:13"x6 1/2"

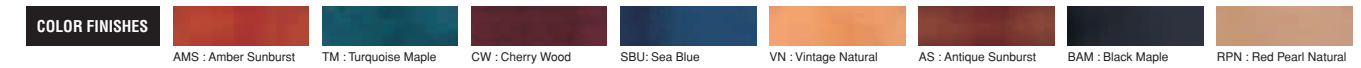

L-Series

“Loud” Concept

Nine vent holes along with the rigid 8-ply oak shell deliver maximum volume and superior low-end tone. Its heavy sound matches its strong appearance.

OAK

Oak's rigidity makes it a hard material to mold. Yamaha's exclusive Air-Seal System however, makes it possible to mold pieces thicker than previously possible, to deliver a heavier sound with excellent durability.



Dark Chrome and Offset Lugs

Dark chrome plating applied to the hoops and lugs produces a bolder, sharper image.



■ NSD1455 Size:14"x5 1/2"

■ NSD1470 Size:14"x7"



●SPECIFICATIONS

| | V-Series | S-Series | | | L-Series | |
|----------|---------------------------------------|-----------------------------------|---------|-------------------------------------|---------------------------------------|---------------------------------------|
| Model | VSD1460 | MSD1455 | MSD1465 | MSD1365 | NSD1455 | NSD1470 |
| Shell | Maple 4ply +Maple 6ply ring | Maple 7ply | | | Oak 8ply | |
| Hoop | Triple flange (steel 1.6mm) w/8 holes | Aluminum Die-cast w/10 holes | | Aluminum Die-cast w/8 holes | Dyna hoop (steel 2.3mm) w/10 holes | |
| Head | Batter | Remo Ambassador Coated | | | | |
| | Bottom | Remo Ambassador Snare | | | | |
| Strainer | Release side | H type | | | | |
| | Butt side | G type | | | | |
| Snare | Hi-carbon steel 20 strands (SN1420CP) | Stainless steel 20 strands (SNRS) | | Stainless steel 14 strands (SN13RS) | Hi-carbon steel 20 strands (SN1420CP) | Hi-carbon steel 25 strands (SN1425CP) |

MAPLE BIRCH OAK

ABSOLUTE (MAPLE CUSTOM ABSOLUTE / BIRCH CUSTOM ABSOLUTE)



64 Solid Silver



59 White Grape Sparkle



61 Midnight Sky Blue

MAS1470, BAS1470 Size: 14"x7"

MAS1460(H), BAS1460(H) Size: 14"x6"

MAS1440 Size: 14"x4"

COLOR FINISHES 24 colors in total
*Refer to the color chart on page 9

OAK CUSTOM

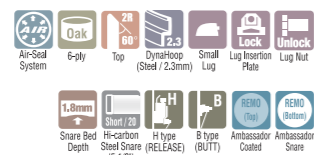

NSD085A Size: 14"x5.5"



TOUR CUSTOM

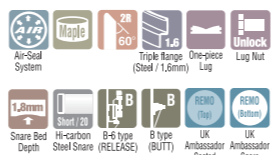

TSD0846 Size: 14"x6"

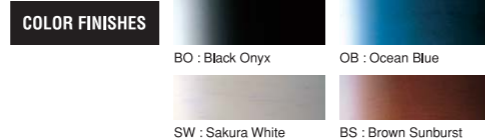

STAGE CUSTOM

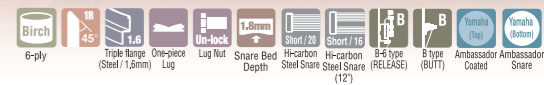

BSD0655 Size: 14"x5.5"

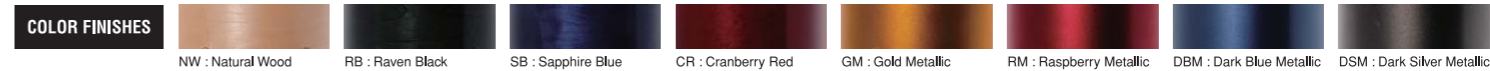

*BSD1250, 1050: Natural Wood (NW) only.

BSD1250* Size: 12"x5"

BSD1050* Size: 10"x5"

MUSASHI

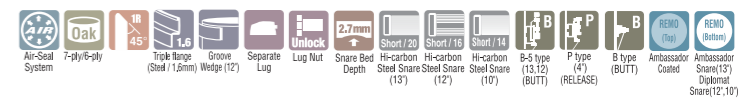

NSD1365M Size: 13"x6 1/2"



NSD1260MBGW Size: 12"x6"

NSD1047M Size: 10"x4 3/4"

●SPECIFICATIONS

| | MAPLE CUSTOM ABSOLUTE | | | BIRCH CUSTOM ABSOLUTE | | OAK CUSTOM |
|----------|---------------------------------------|---------------------------------------|---------|---------------------------------------|---------------------------------------|-----------------------------------|
| Model | MAS1470 | MAS1460(H) | MAS1440 | BAS1470 | BAS1460(H) | NSD085A |
| Shell | Maple 6ply | | | Birch 6ply | | Oak 6ply |
| Hoop | Aluminum Die-cast w/10 holes | | | | | DynaHoop (Steel 2.3mm) W/10 holes |
| Head | Remo Ambassador Coated | | | | | Remo Ambassador Coated |
| | Remo Ambassador Snare | | | | | Remo Ambassador Snare |
| Strainer | H type | | | | | H type |
| | DC type | | | | | B type |
| Snare | Hi-carbon steel 25 strands (SN1425CP) | Hi-carbon steel 20 strands (SN1420CP) | | Hi-carbon steel 25 strands (SN1425CP) | Hi-carbon steel 20 strands (SN1420CP) | Hi-carbon steel 20 strands (SNDH) |

| | TOUR CUSTOM | STAGE CUSTOM | | MUSASHI | | | |
|----------|---------------------------------------|---------------------------------------|---------------------------------------|----------|---------------------------------------|---------------------------------------|-------------------------------------|
| Model | TSD0846 | BSD0655 | BSD1250 | BSD1050 | NSD1365M | NSD1260MBGW | NSD1047M |
| Shell | Maple 6ply | Birch 6ply | | Oak 7ply | | | Oak 6ply |
| Hoop | Triple flange (steel 1.6mm) w/8 holes | Triple flange (steel 1.6mm) w/8 holes | Triple flange (steel 1.6mm) w/6 holes | | Triple flange (steel 1.6mm) w/8 holes | Triple flange (steel 1.6mm) w/6 holes | |
| Head | Remo UK Ambassador Coated | | Yamaha Ambassador Coated | | | | |
| | Remo UK Ambassador Snare | | Yamaha Ambassador Snare | | | | |
| Strainer | Remo Ambassador Snare | | Remo Ambassador Snare | | Remo Ambassador Snare | | |
| | Remo Diplomat Snare | | Remo Diplomat Snare | | | | |
| Type | B type | B-8 type | | | | | |
| | B type | B type | | | | | |
| Snare | Hi-carbon steel 20 strands | | Hi-carbon steel 16 strands | | Hi-carbon steel 14 strands | | |
| | Hi-carbon steel 20 strands | Hi-carbon steel 20 strands | Hi-carbon steel 16 strands | | Hi-carbon steel 20 strands (SN13DH) | Hi-carbon steel 16 strands | Hi-carbon steel 14 strands (SN10DH) |

STEEL

BRASS

COPPER

ALUMINUM



STEEL

BRASS

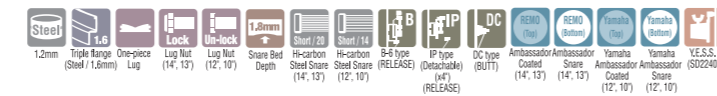

■ SD2465 Size:14"x6 1/2" ■ SD2455 Size:14"x5 1/2" ■ SD2355 Size:13"x5 1/2"

■ SD4470 Size:14"x7" ■ SD4455 Size:14"x5 1/2" ■ SD4440 Size:14"x4"



■ SD2340 Size:13"x4" ■ SD2255 Size:12"x5 1/2" ■ SD2240 Size:12"x4" ■ SD2055 Size:10"x5 1/2"

■ SD4365 Size:13"x6 1/2" ■ SD4355 Size:13"x5 1/2" ■ SD4340 Size:13"x4"

STAGE CUSTOM STEEL

ALUMINUM

COPPER

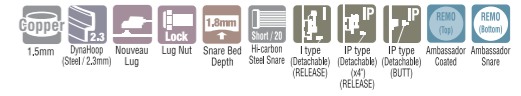

■ SD266A Size:14"x6 1/2" ■ SD265A Size:14"x5 1/2" ■ SD3465 Size:14"x6 1/2" ■ SD3455 Size:14"x5 1/2"

■ SD6465 Size:14"x6 1/2" ■ SD6455 Size:14"x5 1/2" ■ SD6440 Size:14"x4"

Specifications

| | STEEL shells | | | | | | | | | | | |
|----------|---|------------------------|---|---|---|---------------------------|----------------------|--|---|--------|--|--|
| Model | SD2465 | SD2455 | SD2355 | SD2340 | SD2255 (w/Rod Clamp) | SD2240 (w/YESS Rod Clamp) | SD2055 (w/Rod Clamp) | SD266A | SD265A | | | |
| Size | 14"x6 1/2" | 14"x5 1/2" | 13"x5 1/2" | 13"x4" | 12"x5 1/2" | 12"x4" | 10"x5 1/2" | 14"x6 1/2" | 14"x5 1/2" | | | |
| Hoop | Triple flange (steel /1.6mm) with 10 holes | | Triple flange (steel /1.6mm) with 8 holes | | Triple flange (steel /1.6mm) with 6 holes | | | Triple flange (steel /1.6mm) with 10 holes | Triple flange (steel /1.6mm) with 8 holes | | | |
| Lug | SD Lug | | | Piccolo | SD Lug | Piccolo | SD Lug | SD Lug | | | | |
| Lug Nut | Locked | | | | Unlocked | | | | Unlocked | | | |
| Head | Batter | Remo Ambassador Coated | | | Yamaha Ambassador Coated | | | Yamaha Ambassador Coated | | | | |
| | Bottom | Remo Ambassador Snare | | | Yamaha Ambassador Snare | | | Yamaha Ambassador Snare | | | | |
| Strainer | Release side | B-6 type | | IP type (Detachable) | B-6 type | IP type (Detachable) | B-6 type | B-8 type | | | | |
| | Butt side | DC type | | | | DC type | | | | B type | | |
| Snare | Short Hi-carbon steel 20 strands (SN1420CP) | | | Short Hi-carbon steel 20 strands (SN1320CP) | Short Hi-carbon steel 14 strands | | | Short Hi-carbon steel 20 strands | | | | |

| | ALUMINUM shells | | BRASS shells | | | | | COPPER shells | | | |
|----------|---|------------|---|----------------------|---------------------|---|----------------------|---|--------------------------------------|------------|--------|
| Model | SD3465 | SD3455 | SD4470 | SD4455 | SD4440 | SD4365 | SD4355 | SD4340 | SD6465 | SD6455 | SD6440 |
| Size | 14"x6 1/2" | 14"x5 1/2" | 14"x7" | 14"x5 1/2" | 14"x4" | 13"x6 1/2" | 13"x5 1/2" | 13"x4" | 14"x6 1/2" | 14"x5 1/2" | 14"x4" |
| Hoop | DynaHoop (Steel 2.3mm) with 10 holes | | DynaHoop (Steel 2.3mm) with 10 holes | | | DynaHoop (Steel 2.3mm) with 8 holes | | | DynaHoop (Steel 2.3mm) with 10 holes | | |
| Lug | SD Lug | | Nouveau Lug | | | | | Nouveau Lug | | | |
| Lug Nut | Locked (Insertion Plate) | | Locked | | | | | Locked | | | |
| Head | Remo Ambassador Coated | | Remo Ambassador Coated | | | | | Remo Ambassador Coated | | | |
| | Remo Ambassador Snare | | Remo Ambassador Snare | | | | | Remo Ambassador Snare | | | |
| Strainer | I type (Detachable) | | I type (Detachable) | IP type (Detachable) | I type (Detachable) | IP type (Detachable) | IP type (Detachable) | I type (Detachable) | I type (Detachable) | | |
| | IP type (Detachable) | | IP type (Detachable) | | | | | IP type (Detachable) | | | |
| Snare | Short Hi-carbon steel 20 strands (SN1420CP) | | Short Hi-carbon steel 20 strands (SN1420CP) | | | Short Hi-carbon steel 20 strands (SN1320CP) | | Short Hi-carbon steel 20 strands (SN1420CP) | | | |



Yamaha Signature Snare Drums

Mike Bordin Signature Model / Andre Ceccarelli Signature Model / Jimmy Chamberlin Signature Model / Ndugu Chancler Signature Model / Billy Cobham Signature Model / Steve Gadd Signature Model / Sonny Emory Signature Model / Anton Fig Signature Model / David Garibaldi Signature Model / Roy Haynes Signature Model / Akira Jimbo Signature Model / Elvin Jones Signature Model / John "JR" Robinson Signature Model / Steve Jordan Signature Model / Manu Katché Signature Model / Paul Leim Signature Model / Dave Weckl Signature Model

Mike Bordin Signature Model
■SD6465MB
 Copper shell, 14" x 6 1/2", 10-lug, 2.3mm black-finished DynaHoop, hand-hammered bottom half shell; Clear Black finish

"Barks like wood, bites like metal."

MIKE BORDIN

Andre Ceccarelli Signature Model
■MSD1455AC
 Maple shell, 14" x 5 1/2", 4-ply with Reinforcement, 10-lugs, Zinc die-cast hoop, Special chrome, Lime Green Sparkle finish

This drum reflects the strong personality of the top drummer in France. A thinner, 4-ply maple shell is reinforced with 6-ply interior rings, while a 25-strand extra long snare unit covers the entire bottom of the drum, enhancing response. An internal muffler is provided.

ANDRE CECCARELLI

Andre Ceccarelli



Jimmy Chamberlin Signature Model
■SD2455JC
 Steel shell, 14" x 5 1/2", 10-lug, aluminum die-cast hoops; Matte Chrome finish

"This snare drum fulfills all my needs from the lightest shading to the heaviest backbeat! For recording or live, it's my choice."

JIMMY CHAMBERLIN





Ndugu Chancler Signature Model
■SD255ANC
 Steel shell, 14" x 5 1/2", 10-lug, 2.3mm DynaHoop, snare diverter, White finish

"This drum speaks soft with finesse, yet loud with crack. It has the warmth of wood and the power of metal. I need the best of all worlds, and this drum delivers just that."

NDUGU CHANCLER



Ndugu Chancler



Billy Cobham Signature Model
■ASD1460BC
 Maple shell, 14" x 6", 6-ply, 8-lug, 19-ply vintage wood hoop, extended snare; Silver Sparkle or Solid Black finish

"I like a tight, snappy sounding drum, so when you join this shell and vintage hoop with the right drum head combination, the drum almost plays itself."

BILLY COBHAM





Sonny Emory Signature Model
■WSD1455SE
 Beech shell, 14" x 5 1/2", 8-ply/10mm shell, 10-lug, zinc die-cast hoop, special grain, Vintage finish

"All around, it is the most incredible instrument I have ever played!"

SONNY EMORY

Sonny Emory



Anton Fig Signature Model
■MSD14AF
 Maple shell, 14" x 6", 7-ply, 10-lug, 19-ply vintage wood hoop, vintage interior finish, Solid Black finish

"All the engineers and producers flip over the drum - as well as any drummers that have used it!"

ANTON FIG

Anton Fig



Steve Gadd Signature Model
■BSD14ASG
 Birch shell, 14" x 5", 6-ply, 10-lug, black vintage wood hoops, decagonal-shape bottom hoop, 3.5mm snare bed, Solid Black finish

■MSD14ASG
 Maple shell, 14" x 5", 7-ply, 10-lug, black vintage wood hoops, decagonal-shape bottom hoop, 3.5mm snare bed, Solid Black finish

■SD255ASG
 Steel shell, 14" x 5 1/2", 10-lug, black vintage wood hoops, decagonal-shape bottom hoop, 3.5mm snare bed, Black finish

"My signature snare drums all have a wide tuning range. They are designed to work musically in a lot of different situations, responding well to both loose and tight settings. They're everything I want in a snare drum."

STEVE GADD

Steve Gadd



David Garibaldi Signature Model
■SD435ADG
 Brass shell, 14" x 3 1/2", 10-lug, zinc die-cast rims, Blue Nickel Alloy finish

"One major asset of my snare drum is its versatility. Even though it was designed with specific music in mind, it can be tuned in many different ways, making it ideal for many other styles."

DAVID GARIBALDI

David Garibaldi



Roy Haynes Signature Model
■SD655ARH
 Hand-hammered copper shell, 14" x 5 1/2", 10-lug, 2.3mm steel triple-flange rims, internal muffler

"Words cannot express how I feel about my snare drum. From jazz to rock drummers, both young and old, everyone who hears it falls in love with it."

ROY HAYNES

Roy Haynes



Akira Jimbo Signature Model
■WSD13AJ
 Beech shell, 13" x 7", 8-ply, 6-lug, Vintage interior finish, White Sparkle finish

"It is one of the crispiest sounding snare drums in the world. The wood shell and wood hoop combination creates an organic and characteristic tone with a wide dynamic range. You will love this snare with just one shot."

AKIRA JIMBO

Akira Jimbo



Elvin Jones Signature Model
■MSD1470EJ
 Maple shell, 14" x 7", 7-ply, 10-lug, 19-ply vintage hoop, gold lug, Gold Sparkle finish

*Jazz Machine & Musical Legend
 Elvin Jones 1927-2004*

ELVIN JONES

Elvin Jones



Steve Jordan Signature Model
■MSD1365SJ
 Maple shell, 13" x 6 1/2", 4-ply with reinforcement rings, 8-lug, 1.6mm triple-flanged hoop, Matte Natural finish

■SD08CJ
 Birch/mahogany shell, 8" x 5", 7-ply, 5-lugs, YESS mounting bracket, L-arm mounts directly to cocktail drum, Silver Sparkle or Pink Sparkle finish

"This snare drum sounds great, and the maple it is made of is environmentally sound as well. It's acoustically and structurally in tune with Mother Nature."

STEVE JORDAN

Steve Jordan



Manu Katché Signature Model
■SD465AMK
 Black-plated brass shell, 14" x 6 1/2", 10-lug, zinc die-cast top hoop/aluminum die-cast bottom hoop, Black Nickel Alloy finish

■SD455AMK
 Black-plated brass shell, 14" x 5 1/2", 10-lug, zinc die-cast top hoop/aluminum die-cast bottom hoop, Black Nickel Alloy finish

"An instrument speaks your body and soul, so you don't want to be misunderstood when it comes to sensitivity and emotions. My signature snares are exactly what I want to sound like and what I am."

MANU KATCHE

Manu Katché



Paul Leim Signature Model
■SD465APL
 Chrome-plated brass shell, 14" x 6 1/2", black-chromed aluminum die-cast hoops, dual strainer, one-piece gold-plated lugs, 30-strand snares

■SD455APL
 Chrome-plated brass shell, 14" x 5 1/2", black-chromed aluminum die-cast hoops, dual strainer, one-piece gold-plated lugs, 30-strand snares

"My chrome-over-brass snare drums have more brightness, punch, sensitivity, and versatility than anything I've ever used - even the classics."

PAUL LEIM

Paul Leim



John "JR" Robinson Signature Model
■BSD1465NR
 Birch 6ply + Birdseye Maple outer(1ply) shell(Bearing Edge-Top60 ZR/Bottom35 R1), 14" x 6 1/2", 20 copper nails embedded in batter side of shell, Amber Sunburst finish

"With all the great engineers at Yamaha Drums, I designed the snare drum of my dreams. This 14" x 6 & 1/2" amber sunburst beauty does everything I ask, from a 60 piece orchestra with Barbra Streisand to my rock trio, TRW. This is the one and only snare I will ever need" - John "JR" Robinson

JOHN "JR" ROBINSON

John "JR" Robinson



Dave Weckl Signature Model
■MSD14ADW
 Maple shell, 14" x 5 1/2", 8-lug, Nouveau lug casings, aluminum die-cast hoops, dual strainer design, Solid Black finish

■MSD13ADW
 Maple shell, 13" x 5 1/2", 6-lug, Nouveau lug casings, aluminum die-cast hoops, dual strainer design, Solid Black finish

"Having two independent snare strainers, these drums are unique in design. The combination of tight tension on the hi-carbon snares, with the loose tension on the stainless steel snares, provides both the precision necessary for sharp and clean strokes with an open airy sound. It is the best of both worlds in one drum!"

DAVE WECKL

Dave Weckl



Yamaha Drummers in the World



Sam Acard
Cornell College, Ithaca



Marcus Baylor
Yellowjackets



Tom Brechtlein
Chuck Corea, Robert Ford



Keith Carlock
Sade, Dan



Kit Cratham
Carpenter, Skillet's Coreo



Zach Danziger
Blauner, Randy Brecker, Brian



Matt Flynn
Mason 5



Clint de Canon
Art Garfunkel



Wolfgang Hafner
David Lee Roth, The Allman Brothers Band, The Grateful Dead, The Blues Brothers



Richard Hughes
Keano



Victor Jones
Drzyk, Kasper, Murrain Wilson, Chick Corea



Ralph MacDonald
Jimmy Buffet



Craig MacIntyre
John Gooden



Charly Alberti
Sopa Stereo



Carter Beauford
Dave Matthews Band



Ray Brinker
Timothy Sullivan



Terril Lyne Carrington
Helen Reddy



Swiss Chris
John Legend



Charley Drayton
Fiona Apple, Michelle Branch

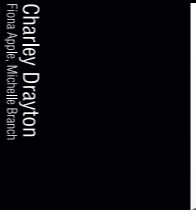

Abe Fogle
Red Thomas

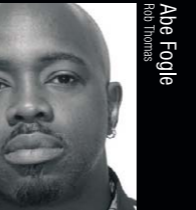

David Garibaldi
Tower of Power



Stefan Halperin
Klezmer



Ralph Humphrey
Darius Rucker, The Roots, Los Angeles Music Academy



Willie Jones III
Roy Hargrove



Steve Jordan
Eric Clapton, Sam Cooke, Sly & The Family Stone



Jerry Marotta
Independent



Tommy Aldridge
Whitesnake



Ignacio Berrera
Gonzalo Rubalcaba



Paul Brochu
UZES, Eric Vanelli Band



Bruno Castellucci
Toto's Thinkers, Anne Ducros



Mino Cirielu
Miles Davis, Sting, David Sanborn



Phil Erhart
Kallias

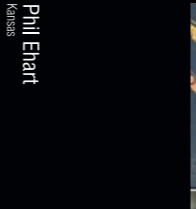

Justin Foley
Killswitch Engage

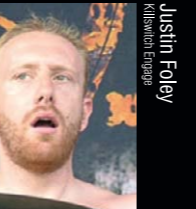

Bill Gibson
Henry Lewis & The Venus



Eric Harland
Josselyn Beaudry



Steve Hutchinison
Darius Rucker



Steve Jordan
Eric Clapton, Sam Cooke, Sly & The Family Stone



Rick Marotta
Independent



Manu Katche
Sting, Peter Dinklage, Jan Garbarek



Zachary Alford
Gwen Stefani



Gerry Brown
Diana Ross



André Cecarelli
Independent



Billy Cobham
Independent



Sonny Enroy
Bruce Hornsby, Belle Miller

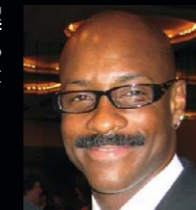

Shannon Forest
Faith Hill



Marcus Gilmore
Chuck Corea

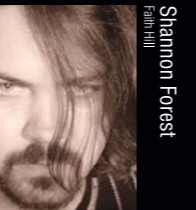

Steve Hass
John Scofield

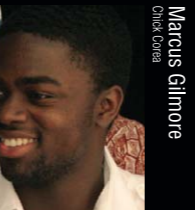

Susie Ibarra
Independent



Dave Matacks
New Orleans, Capitol, Paul McCartney, Eric Clapton



Russ Kunkel
U2, Led Zeppelin, James Taylor



Chris McHugh
Kelli Underhill



Chris Kunkel
U2, Led Zeppelin, James Taylor

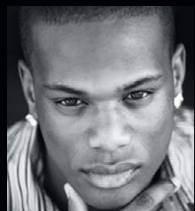

Nathan Allen
Independent



Bobby Blotzer
BATT



Jimmy Chamberlin
Smashing Pumpkins, The Jolly Chameleon Complex



Aaron Comess
Spin Doctors



Sully ERA
Guns N' Roses



Samuel Formell
Les Van Van



Nikki Glaspie
Beatrice



Roy Haynes
Herb Alpert



Ali Jackson
Wynton Marsalis



Akira Jimbo
Hiroshi Ueda, Hallelujah Jazz, Independent



Shannon Larkin
Guns N' Roses

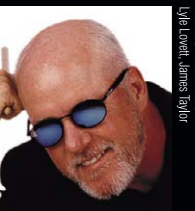

Ed Lay
Edits



Chris Johnson
Katherine McPhee, Steve Wonder



Cliff Almond
The Dillards, Arno Vinea, Michael Camillo



Matt Cameron
Pearl Jam, Sound Garden



Will Champion
Coldplay



Caroline Corr
The Corrs



Susan Evans
Peter, Paul and Mary



Al Foster
McCoy Tyner, Miles Davis



Robbie Gonzalez
Gato Barbieri

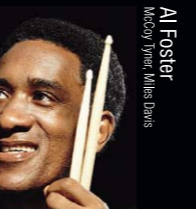

Chris Hesse
Horseshoe



Ari Hoenig
Kenny Werner, Wojan Kertesz



Chris Johnson
Katherine McPhee, Steve Wonder



Chaun Horton
Mary Gery



Kenney Jones
The Jones Gang, The Who



Paul Leim
Nashville Sound, Steve Van Zandt, Larry Carlton, Frank Zappa



Michael Baker
Whitney Houston, Bruce Hornsby



Jimmy Brantly
Orlando Hitz



Gordon Campbell
Independent



Ndugu Chanler
Independent



Kirk Covington
Independent



Johnny Fay
Tradegully HD



Anton Fig
Late Show with David Letterman



Steve Gadd
Paul Simon, Eric Clapton, James Taylor



Ralf Guske
Nadine S. Ina Marnheims, Nannini



Eddie Bayers
Nashville Studio



Mike Braun
Hall and Oates



Oliver Charles
Earl Hines & The Incoherent Criminals



Mickey Curry
Byron Adams



Eddie Bayers
Nashville Studio



Mike Braun
Hall and Oates



Oliver Charles
Earl Hines & The Incoherent Criminals



Teddy Campbell
American Idol



Mickey Curry
Byron Adams



Anton Fig
Late Show with David Letterman



Steve Gadd
Paul Simon, Eric Clapton, James Taylor



Ralf Guske
Nadine S. Ina Marnheims, Nannini



Chaun Horton
Mary Gery



Kenney Jones
The Jones Gang, The Who



Paul Leim
Nashville Sound, Steve Van Zandt, Larry Carlton, Frank Zappa



Steve McKie
Bill



Steve McKie
Bill

Yamaha Drummers in the World



Dominique Messier
Celine Dion
Independent



Gary Novak
Independent



Prairie Prince
The Roots, Jefferson Starship, Todd Rundgren



Antonio Sanchez
Pat Metheny



Andrew Small
Massive Attack, Independent



Martin Valhøra
Horn Trio



Joey Williams
Mother's Finest

AUSTRALIA

Dave Haley
Gordon Rytmeister
Shane Wakker

CANADA

Steve Augustine
Yanic Bercier
Julien Blais
Randy Cooke
Benjamin Dussault
Matt Frenette
Mark Kelso
Mercedes Lander
Wilson Laurencin
Gabe Mantel
Mark Mc Lean
Mike Michalkow
Eric Paul
Jason Pierce
Vito Rezza
Daryll Stephens
Al Webster

FRANCE

Roger Biwandu
Hervé 'RV' Coquerel
Daniel Humair
Loïc Pontieux

GERMANY

Bela B.
Bruno Castellucci
Rainer Schumann

INDONESIA

Gilang Ramadhan

ITALY

Christian Meyer

JAPAN

Satoshi Bando
Nobuo Eguchi
Himawari
Takeshi Inomata
Masaharu Ishikawa
Toshihiro Niimi
Hiroyuki Noritake
Masahiko Osaka
George Otsuka
Kiyohiko Semba
Eiji Shimamura
Kozo Suganuma

MEXICO

Alfonso Andre
Randy Ebright
Enrique Gonzalez

NETHERLANDS

Ron v. Stratum

POLAND

Michal Dabrowka

SCANDANAVIA

Ian Hauglund
Erik Smith

SPAIN

Patty Ballinas
Pedro Barceló
Jose Bruno
Jose Mena
Miguel Morales
Javier Reija

UK

Ben Carrigan
Derrick Mckenzie
Mark Mondesir
Gary Powell
Neal Primrose
Aled Richards
Chuck Sabo
Andrew Small
Ian Thomas
Neal Wilkinson
Ed Lay
Stephen Halpburin
Nathen Allen
Troy Miller
Sam Agard
Ash Soan

USA

Ludwig Afonso
Alex Alexander
Carl Albrecht
Vinnie Amico
Horacee Arnold
Doug Belote
Bogie Bowles
Robert Breithaupt
Jim Campbell
Gorden Campbell
Gary Chaffee
Dave Chavarri
Vince Cherico
Leroy Clouden
Glendon Crain
Dennis Davis
Marc Dicciani
Kimati Dinzulu
Peter Donald
Tony Escapa
Loraine Faina
Gregg Field
Patrick Forero
Brian Fullen
Dick Gay
MB Gordy
Art Gore
Michael Gould
Jamey Haddad
Marvin (Slam G's) Hammett
Dana Hall
Ivan Hampden
Tommy Harden
Dave Harrison
Steve Hass
Brendan Hill
Robin Horn
Gary Hobbs
Andy Hubbard
Brian Ireland
John "Jabo" Starks
Ralph Johnson
Mike Kennedy
Tom Knight
Karl Latham
Larry Lelli
Stacy Lones
Chris Lukes
Larry Levine
Pete Magadini
John Mahon
David Mancini
Sherrie Maricle
Dave McAfee
Jack Mouse
Sean McCurley
Marvin McQuitty
Scott Mercado
Rich Mercurio
Allison Miller
Moke
T.S. Monk
Rick Montalbano
Tony Moore
Calvin Napper
Dan Needham
Sean Paddock
Jim Peterscak
John Riley
Ed Soph
Clyde Stubblefield
Rodrigo Villanueva
Calvin Rodgers
Charles Ruggiero
Allan Schwartzberg
Herb Shucher
Joe Sirois
Marc Slutsky
Joel Stevenett
Donald Tardy
Jamey Tate
Kimberly Thompson
Dave Tull
Nick Vincent
Todd Wolf
Lonnie Wilson
Doug Yowell



Mark Mondesir
Independent



Jamie Orlaker
Independent



Questlove
The Roots



Neil Sanderson
The Roots



Ash Soan
The Roots, Madeline Bellfield



Tony Verderosa
Independent



Brian Wolff
Diep

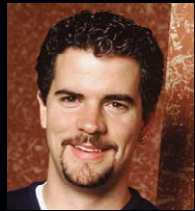

Russ Miller
Independent, LA Studio



Chris Parker
Booker T. Jones, Miles Davis, Bad Company, MC Bratley



Marcus Randolph
Robert Randolph & The Family Band



Steve Schaeffer
LA Studio



Chad Szeliga
Booker T. Jones



Brian Vialtone
The Dresden Dolls



Chad Wright
High School Musical



Aaron Montgomery
Tropi



Khari Parker
Bee Seeps



Mark Richardson
Lille, Angeles, Spunk, Avenue, Feeder



George Schwirndt
Edguy, Kallu



Akira Tana
Tana Tana



Chris Venna
Gracie Skyline



Ben Wysocki
The Frey



Richie Morales
Miles Stern, Stryker, Giza, SLINY, Panchase

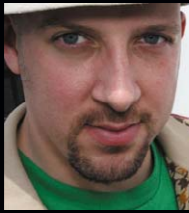

Charlie Paxson
Celine Dion



Karrim Higgins
Common, Roy, Hightower, Ray Brown



Kendrick Scott
Fantasia Barrino



Ian Thomas
Independent



Mark Walker
Pavlov, D'Rivera



Jon Wysocki
Stand



Larry Mullen, Jr.
U2



Felix D'cat Pollard
Taylor Hicks



Ben Riley
The Roots, Mark, Ben Carter, Quana, Sphere



Oscar Seaton
George Benson, Leon Fichbe



Kimberly Thompson
Miles Stern, Beyonce



Dave Weckl
Dave Weckl Band, Chick Corea



Xavier Murrell
Booker T.



Gary Powell
Dirty Pretty Things



John Robinson
Independent, LA Studio



Mike Shapiro
Sergio Mendez



Adam Topol
Jack Johnson



Vincent Wilburn Jr.
Miles Davis, Independent



Andrew Newmark
Sly & The Family Stone, Roger Waters, Studio



Darnis Prieto
Michael Camillo



Ralph Rolle
Live at the Apollo



Anandan Sivamani
Independent



Zacky Tsoukas
Independent



Buddy Williams
Mannheim Tansel, George Benson



YAMAHA SYSTEM HARDWARE

Hardware should maximize the performance and capabilities of the drum. Drummers worldwide have long held Yamaha hardware in high regard for its outstanding durability and reliability. New products like our pattern-less footboards and mechanically strong hex pipe were each conceived from ideas brought to us by individual players. As times, music, players, and possibilities evolve, so does Yamaha System Hardware.

Foot Pedal
Hi-hat Stand
Cymbal Stand
Snare Stand
Drum Stool
Tom Holder
Double Tom Stand
HEXRACK

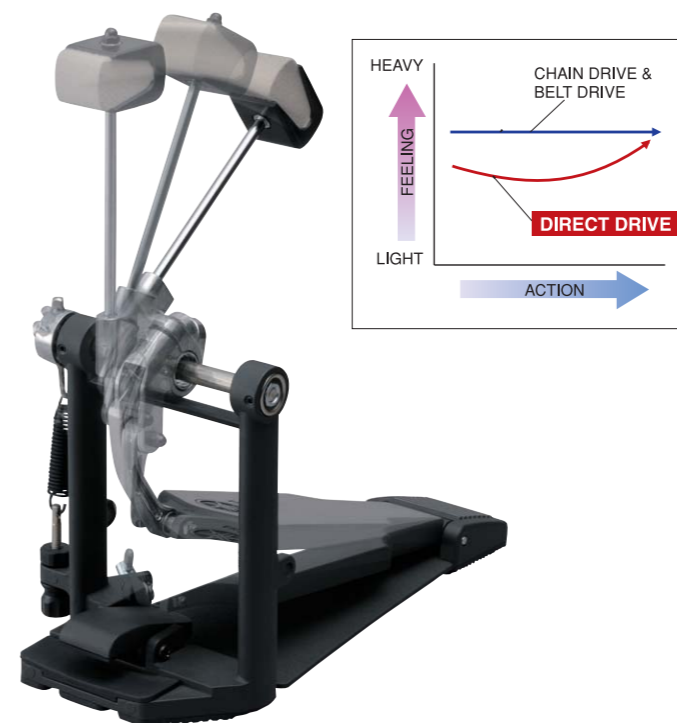

■ In Pursuit of Smooth Action (FP9500D Series)

The FP9500D's light pedal work is made possible through the utilization of an aluminum die-cast link. The pedal stroke starts out light when pressed but delivers dynamic pedal action with an overwhelming sense of speed. (FP9500D, FP9500D)

■ New Footboard Design

The wider pedal design provides a larger contact surface for your foot delivering a lighter feel and greater playability. Grip is enhanced in the heel section, and the pattern-less surface offers both moderate gripping and smooth movement. A weight balance on the end delivers great playability. (FP9500 series, DFP8500 series, DFP series) The FP8500C/8500B both feature longer footboards. The same length as used on the hi-hat pedals offers smoother switching to the sub pedal.

4 Drive System Types

Four Drive Types Offer Four Different Feels

Direct Drive

9500D

A die-cast aluminum link provides a direct connection between the pedal and beater that transmits pedal control directly to the beater. This high performance drive delivers an overwhelming sense of speed. (FP9500D, DFP9500D)

Double Chain Drive

9500C, 8500C

The double chain drive offers reliable and durable operation with uniform action. The FP9500C/8500C and DFP9500C/9500CL come with a belt letting you switch to a belt drive system if preferred.

Single Chain Drive

7210A

The single chain drive provides uniform action with a natural feel.

Belt Drive

8500B

The belt drive has supple touch and feel that isn't found in chain drive systems.

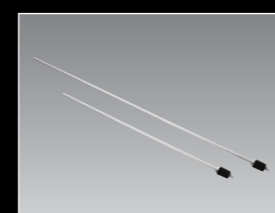
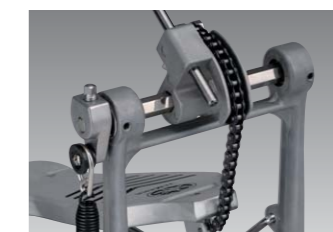

Footboard

Big Rubber Feet and Spikes

Pipe Lock System

Long & Regular Rods

Hex Pipe

Pedal

Single Foot Pedal
FP9500C



Double Foot Pedal
DFP9500C



Single Foot Pedal
FP9500D



Double Foot Pedal
DFP9500CL

Double Foot Pedal
DFP9500D



Single Foot Pedal
FP8500C



Double Foot Pedal
DFP8500C



Single Foot Pedal
FP8500B



Single Foot Pedal
FP7210A



Specification List

| | Direct Drive | | Double Chain Drive | | | Belt Drive | Single Chain Drive |
|-------------------------------|--------------|----------|---------------------------------|---|---------|-------------------------------|-------------------------------|
| | FP9500D | DFP9500D | (Convertible to the Belt Drive) | | FP8500C | DFP8500C | FP7210A |
| | FP9500C | DFP9500C | DFP9500CL (L Type) | | | | |
| Yamaha Base Plate | ● | ● | ● | ● | ● | (Linked with connecting rods) | (Linked with connecting rods) |
| Semi-Hard Case | ● | ● | ● | ● | ● | ● | ● |
| Yamaha's Frame Design | ● | ● | ● | ● | ● | ● | ● |
| BD Hoop Clamp System | ● | ● | ● | ● | ● | ● | ● |
| Foot Board Angle Adjustment | ● | ● | ● | ● | ● | ● | ● |
| Patternless Foot Board | ● | ● | ● | ● | ● | ● | ● |
| Tear Drop Beater Shaft Rocker | ● | ● | ● | ● | ● | ● | ● |
| Beater Angle Adjustment | ● | ● | ● | ● | ● | ● | ● |
| Spring Roller with Bearings | ● | ● | ● | ● | ● | ● | ● |
| Spring Adjust Lock System | ● | ● | ● | ● | ● | ● | ● |
| Long Foot Board | — | — | — | — | ● | ● | — |
| 2way Beater | ● | ● | ● | ● | — | — | — |

Option



Yamaha System Hardware Analysis



2-Way Beater

This convertible beater incorporates two types of beaters into a single unit. One side is a normal felt type while the other is made of plastic that delivers a feeling close to wood. (FP9500, DFP9500 series)

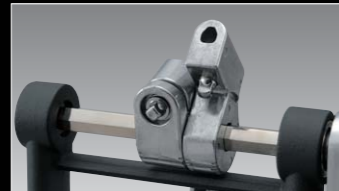

Beater Shaft Rocker (Pat. Pend.)

The teardrop shaped shaft hole holds the shaft securely. (All models)
The shaft's flat surface keeps the 2-way beater from swiveling while playing.



Spring Roller with Built-in Bearings

Precision bearings deliver smooth, natural pedal action. (Excluding the 7210A)



Base Frame Tie Rods

Rubber coated tie rod ends prevent the footboard and base frame from becoming disconnected.

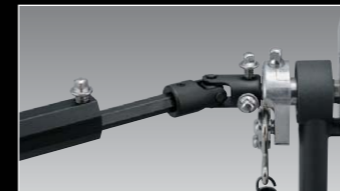

Smooth Moving Universal Joint

A universal joint on the rocker shaft provides angular flexibility for smoother movement. (All models with double foot pedals).

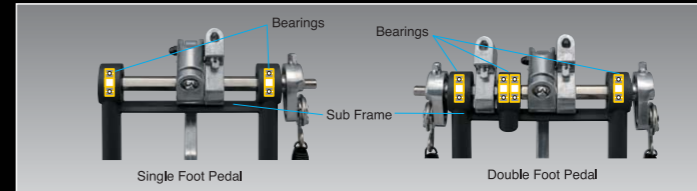

Frame Structure

This Yamaha original design incorporates a sub-frame just below the rocker shaft to deliver greater stability and durability. Drummers will experience smoother, more stable movement particularly in double pedal setups since bearings for both the main and remote beaters are incorporated into the sub-frame. (All models)



Compact and Convenient Semi-Hard Case

The 9500 Series pedals come with a specially designed semi hard case. This case provides protection from damage even when storing the pedals in the trunk case along with the stands that are missing their rubber feet. (FP9500 series, DFP9500 series)



Beater Angle Adjustment

Loosening the adjustment screw lets you freely adjust the beater angle along with the footboard angle. (All models)

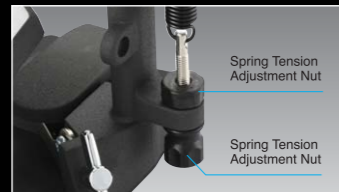

Spring Tension Adjustment Lock System

One hand spring tension adjustment is easy. A lock bolt secures the setting to prevent loosening during play. (Excluding the 7210A)



Footboard Angle Adjustment

The pedal angle can be set freely to any angle without affecting beater angle. This lets you set the pedal angle you want when the pedal is not pressed. A tuning key is used to make the adjustment, which also lets you align pedal height with your sub, and hi-hat pedals. (FP/DFP9500 Series)



Bass Drum Hoop Clamp

A wing bolt firmly tightens the clamp for secure attachment. It also allows the clamp to accommodate different hoop thicknesses.

Hi-Hat Stand



Hi-Hat Stand
HS1200T



Hi-Hat Stand
HS1200

Hi-Hat Stand
HS1200D

Hi-Hat Stand
HS850

| Model No. | HS1200T | HS1200D | HS1200 | HS850 | HS740A | HS650A |
|-----------------------------|----------------------|----------------------|--|---|---|---|
| Available Height Range | 74 ~ 105cm | 74 ~ 105cm | 74 ~ 105cm | 70 ~ 92cm | 70 ~ 90cm | 65 ~ 90cm |
| Locking Hi-hat Clutch | ● | ● | ● | — | — | — |
| Cymbal Support | Hard Rubber / Felt | Hard Rubber / Felt | Hard Rubber | Felt | Felt | Felt |
| Cymbal Angle Adjustment | ● (w/Fixing Nut) | ● (w/Fixing Nut) | ● (w/Fixing Nut) | ● | ● | ● |
| Rotating Leg Design | ● | ● | ● | ● | ● | — |
| Spring Tension Adjustment | ● (with Indicator) | ● (with Indicator) | ● (with Indicator) | ● | ● (11 Increments) | — |
| Foot Board Angle Adjustment | ● | ● | ● | — | — | — |
| Toggle Link System | ● | — | — | — | — | — |
| Big Rubber Feet | ● (with Spike) | ● (with Spike) | ● (with Spike) | ● | ● | (Normal) |
| Leg Design | 2 Double Braced Legs | 2 Double Braced Legs | 3 Double/Single Braced Legs (Pedal Side Legs Open 150) | 3 Double Braced Legs (Pedal Side Legs Open 150) | 3 Single Braced Legs (Pedal Side Legs Open 150) | 3 Single Braced Legs (Pedal Side Legs Open 120) |
| Rod Length | Long & Regular Rod | Long & Regular Rod | Long & Regular Rod | Regular Rod | Regular Rod | Regular Rod |



Hi-Hat Stand
HS740A



Hi-Hat Stand
HS650A

Option

Remote Wire Hi-hats **WHS860** (2.5m)

The WHS860 and WHS860S remote wire hi-hats offer independent positioning of hi-hat and the hi-hat pedal. The system features a unique drop clutch mechanism that closes the hi-hat with the tap of a stick, freeing your hi-hat foot to play other pedals. Pressing the hi-hat foot pedal restores normal operation. An AC910 arm clamp (sold separately) holds the hi-hat unit in place and offers maximum flexibility in positioning. The WHS860S is a short cable (1m) version.



Drop Clutch **OCR910**

Yamaha's sophisticated drop clutch mechanism releases the hi-hat with the tap of a stick and returns it to normal operation by depressing the foot pedal.



Hi-Hat Attachment **HSAT930**

Connects the sub-pedal of a double-bass foot pedal to the hi-hat stand to prevent pedal slippage.(for HS1100, 1000, 950 only)



Closed Hi-hat Holder **CHH930** **NEW**

Position a hi-hat in your setup anywhere you like. Spring tension is adjustable.



Yamaha System Hardware Analysis

Toggle Link System

The toggle link system on the HS1200T offers light and nimble pedal work. The first part of the pedal stroke feels really light but becomes increasingly heavier and closer to normal weight as the pedal stroke progresses. There is also little impact on the frame when the foot is removed from the pedal and the system delivers quiet operation. (HS1200T)



(1) Compared to normal direct link systems, the feeling is very light at the top of the stroke. And even if spring tension is increased, the amount of power required at the top of the stroke does not change.

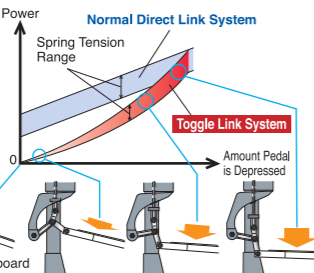

(2) As the pedal is further depressed, it starts to react more like a normal direct link system with the end of the stroke feeling nearly the same as a normal direct link pedal. The peculiar action produced by this power enhancing system (lever, etc.) decreases as the pedal is depressed.

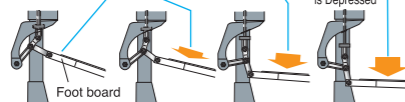

Big Rubber Feet and Spikes

A push-lock spike incorporated into the large rubber feet offer additional stopping power. Extending and retracting the spikes are as easy as pressing the push lock. (HS1200T, 1200D, 1200)



Cymbal Holder and Angle Adjustment

The reversible design features felt on one side and rubber on the other, and can be switched according to your needs. Also, a newly designed angle adjustment screw automatically locks after adjustment to prevent loosening during performance. (HS1200T, 1200D, 1200)



Drum Key Holder

Keep your drum key in the handy holder on the stand's pipe. (HS1200T, 1200D, 1200)



Single and Double Braced Legs

A double-braced center leg and single-braced side legs provide stability while reducing interference with adjacent stands in your setup. (HS1200)



Spring Tension Adjustment

Spring tension adjustment (the force that opens the top cymbal) is quick with the large dial. The new design makes it easy to rotate and an indicator located under the dial gives you a visual indication of the amount of tension set. (HS1200T, 1200D, 1200)

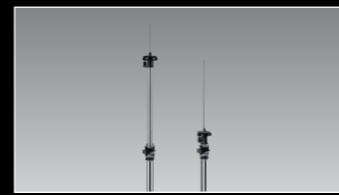

Long and Regular Rods

Hi-hat cymbal height
With long rod: 739.5mm-1052mm
With Regular rod: 739.5mm-902mm
Two rods, one long one supplied to accommodate lower plating positions.



Footboard Angle Adjustment

Pedal angle, when not depressed, can be set freely. This lets you align pedal height with other pedals such as in a double foot pedal setup. Rubber coated tie rods help to prevent pedal hopping. (HS1200T, 1200D, 1200)



Footboard

The new wider pedal design provides a greater contact surface for your foot delivering a lighter feel and greater playability. Grip is enhanced in the heel section, and the pattern-less surface provides both moderate gripping and smooth movement. A weight balance on the end delivers great playability. Slim form allows closer setting of the double foot pedal. (HS1200T, 1200D, 1200)

Hi-Hat Attachment **HSAT910**

The HSAT910 connects a hi-hat stand, with its legs folded, to the bass drum in double bass drum setups.



NEW Locking Hi-hat Clutch **LC930A**

Locking clutch eliminates loose cymbals. Angled lock key bolts make tightening easier. (HS1200 series)



Extension Rod **EX910**

This extension rod adds an extra 4" (10cm) of height to the hi-hat stand.



NEW Hi-hat Clutch **LC810A**



Cymbal Stand



| Model No. | CS965 | CS865 | CS755 | CS665A | CS655A | CS850 | CS750 | CS660A | CS650A |
|------------------------|----------------------|----------------------|----------------------|----------------------|----------------------|----------------------|----------------------|----------------------|----------------------|
| Available Height Range | 91 ~ 172cm | 94 ~ 175cm | 91 ~ 172cm | 80 ~ 163cm | 79 ~ 162cm | 73 ~ 154cm | 73 ~ 154cm | 63 ~ 146cm | 62 ~ 145cm |
| Offset Tilter | — | — | — | ● | ● | — | — | ● | ● |
| Center Tilter | — | — | ● | — | — | — | ● | — | — |
| New Step Free Tilter | ● | ● | — | — | — | ● | — | — | — |
| Big Rubber Feet | ● | ● | ● | — | — | ● | ● | — | — |
| Leg Design | 3 Double Braced Legs | 3 Double Braced Legs | 3 Double Braced Legs | 3 Double Braced Legs | 3 Single Braced Legs | 3 Double Braced Legs | 3 Single Braced Legs | 3 Double Braced Legs | 3 Single Braced Legs |

Boom Cymbal Stand
CS965 NEW

Boom Cymbal Stand
CS865 NEW

Boom Cymbal Stand
CS755

Straight Cymbal Stand
CS850 NEW

Straight Cymbal Stand
CS750

Straight Cymbal Stand
CS660A

Straight Cymbal Stand
CS650A

Boom Cymbal Stand
CS665A

Boom Cymbal Stand
CS655A

Option

Cymbal Stand Boom Weight CSBW NEW

Cymbal Stand Attachment CSAT942

The CSAT942 connects to the tilter and offers fine angle adjustment.

Cymbal Stand Attachment CSAT940

The CSAT940 can be used for two stage cymbal arrangements or a closed hi-hat arrangement.

Cymbal Stand Attachment CSAT926A

This example shows a tom holder and cymbal holder attached to a CSAT926A (both sold separately).

The CSAT926A only connects to 22.2mm diameter pipes.

Cymbal Stand Attachment CSAT924A

The CSAT924A connects to the pipes of stands and holders allowing a wide variety of set-ups and positions to be easily achieved.

Cymbal Holder CH750 **Cymbal Holder CH755** **Cowbell Holder CWH940** **Cowbell Holder CWH910**

* The CSAT940 and CSAT942 attach to cymbal stands and holders (except the CS655A, CS650A, CS660A, CS665A).

Yamaha System Hardware Analysis

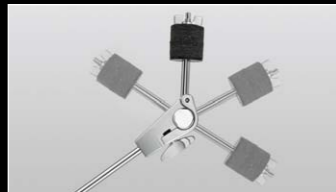

New Step Free Tilter

Step free angle adjustment lets you set the cymbal at any position you like. Supporting the cymbal's weight in the center of the pipe provides a more stable setting. (CS900 Series, CS800 Series)



Center Tilter

The Center Tilter, long popular among knowledgeable players, has been revived in the CS700/CH700 Series, CSAT942/940 and CWH940 series. By supporting the weight of the cymbal at the center, greater stability is achieved.

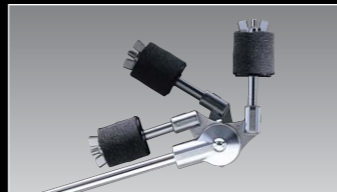

Offset Tilter

The offset tilter stores parallel to the pipe making transport easy and preventing damage. This tilter is used in the 600 series, which is noted for its light, compact design.



Placing Type Boom Tilter Mechanism

Retaining YAMAHA's traditional gear mechanism, we now introduce the "clipping" method for securing the boom arm. Through this specification, the main unit of the boom arm becomes more resistant to scratches. It ensures extra peace of mind, even during complex setup adjustments. It begins with the CS965, 865, 755, CH755, 750.

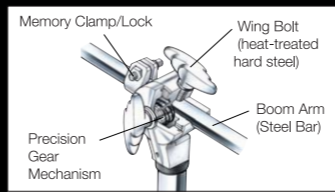

Pressing type Boom Tilter Mechanism

A precision gear mechanism provides precise adjustment of the boom arm's angle. A wing bolt firmly fixes the boom arm in place while a memory clamp/lock offers quick positioning and prevents rotating. (CS665A, 655A)

Small Wing Nut, Tilter Sleeve & Felt

A polycarbonate tilter sleeve encases just enough of the head bolt to provide optimum securing of the cymbal. Utilization of a wing nut lets you play the cymbal bell without it getting in the way of the stick.

Boom Cymbal Holder

Yamaha's cymbal holder fits into the main pipe making it easier to pack and transport.

Tight & Secure

Specially designed by Yamaha, the nylon bushing holds the pipe firmly in place even when lightly tightened. Since the wing bolt is tightened through a steel nut, the durability of the bolt is increased. (All models)

Big Rubber Feet

In addition to wide stance legs, the big rubber feet supply maximum non-slip grip to keep the stand firmly in place.

Unified Diameter Center Pipe

The center tube assembly accommodates the same 22.2mm diameter pipe as found on other stands so you can replace the upper tube assembly with that of another cymbal stand or tom holder. (except CS655A, CS650A)

Snare Stands

| Model No. | SS950 | SS850 | SS740A | SS662 |
|-------------------------|----------------------|----------------------|----------------------|-----------------------------|
| Available Height Range | 45 ~ 61cm | 45 ~ 63cm | 45 ~ 61cm | 43 ~ 62cm |
| Rubber Arms | 3 Arms | 3 Arms | 3 Arms | 3 Arms (for 12" Snare Drum) |
| Adjustable Angle Tilter | ● | — | — | — |
| Big Rubber Feet | ● (With Spike) | ● | ● | — |
| Leg Design | 3 Double Braced Legs | 3 Double Braced Legs | 3 Single Braced Legs | 3 Single Braced Legs |



Snare Stand
SS950 NEW



Snare Stand
SS850 NEW



Snare Stand
SS740A



Snare Stand (for 12")
SS662



Snare Basket Adjustment Knob
Improved grip design delivers great gripping power.



Adjustable Angle Tilter
Snare angle adjustment is speedy and flexible. Yamaha's exclusive Ball Clamp design on the SS950 lets you set your snare at any angle you like. The large wing bolt tightens securely to hold the angle.



Big Rubber Feet and Spikes
In addition to the wide leg stance, the big rubber feet deliver maximum grip to hold the stand securely in place.

Stools

| Model No. | DS950 | DS840 | DS750 | DS550U |
|-------------------|--|-----------------------------------|-----------------------------------|--|
| Seat | Large Square Seat Design 480(W)x390(D)mm | Round Seat Design 330mm(Diameter) | Round Seat Design 300mm(Diameter) | Round Seat Design 300mm(Diameter) |
| Seat Mount | Large AL Die-cast Seat Mount | Large AL Die-cast Seat Mount | AL Die-cast Seat Mount | AL Die-cast Seat Mount |
| Height Adjustment | Screw Rod (460 ~ 650mm) | Screw Rod (460 ~ 650mm) | Clamp Rod Type (430 ~ 650mm) | Clamp Rod Type (420 ~ 600mm) (no hole, w/memory clamp) |
| Leg Ass'y | 4 Double Braced Wide Stance Legs | 3 Double Braced Wide Stance Legs | 3 Double Braced Legs | 3 Single Braced Legs |



Large Seat Mount
(480mm x 390mm)

Four Double Legs

Big Rubber Feet

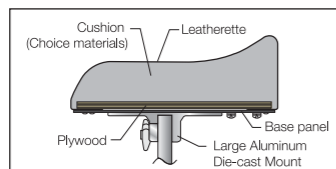

Cushion (Choice materials)
Leatherette
Base panel
Plywood
Large Aluminum Die-cast Mount



Drum Stool
DS840



Drum Stool
DS750



Drum Stool
DS550U



Back Support
BK5110



Large Seat Mount
Aluminum die-cast type. Offers great stability and durability. (DS950, 840)

Tom Holders

Ball Mount & Clamp

The Yamaha original ball mount and clamp system offers unparalleled flexibility and ease of positioning. A generous sized hard synthetic resin ball sits in an attractive chromed housing that permits the tom hex rod to be positioned in almost any imaginable position. The ball joint friction-free operation provides ease of set up, while a large wing bolt provides one touch locking.

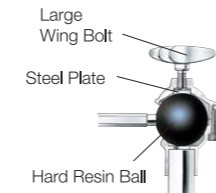

Cap

The cap reduces noise and protects the holder when no tom clamp is inserted.

Pipe Cap

Cap eliminates unnecessary vibrations from the bass drum.

Memory Clamp

Attaching the clamp at an ideal position reduces setup time. Helps eliminate rattle and noise and can be used inverted.



Triple Tom Holder

The Yamaha triangular triple tom holder expands the range of possibilities for creative setups. Cymbals or tom toms can be added as your style demands.

Cap eliminates unnecessary vibrations from the bass drum.

Cap eliminates unnecessary vibrations from the bass drum.

Cap eliminates unnecessary vibrations from the bass drum.

Cap eliminates unnecessary vibrations from the bass drum.

Cap eliminates unnecessary vibrations from the bass drum.

Cap eliminates unnecessary vibrations from the bass drum.

Cap eliminates unnecessary vibrations from the bass drum.

Cap eliminates unnecessary vibrations from the bass drum.

Cap eliminates unnecessary vibrations from the bass drum.

Cap eliminates unnecessary vibrations from the bass drum.

Cap eliminates unnecessary vibrations from the bass drum.

Cap eliminates unnecessary vibrations from the bass drum.

Cap eliminates unnecessary vibrations from the bass drum.

Cap eliminates unnecessary vibrations from the bass drum.

Cap eliminates unnecessary vibrations from the bass drum.

Cap eliminates unnecessary vibrations from the bass drum.

Cap eliminates unnecessary vibrations from the bass drum.

Cap eliminates unnecessary vibrations from the bass drum.

Cap eliminates unnecessary vibrations from the bass drum.

Cap eliminates unnecessary vibrations from the bass drum.

Cap eliminates unnecessary vibrations from the bass drum.

Cap eliminates unnecessary vibrations from the bass drum.

Cap eliminates unnecessary vibrations from the bass drum.

Cap eliminates unnecessary vibrations from the bass drum.

Cap eliminates unnecessary vibrations from the bass drum.

Cap eliminates unnecessary vibrations from the bass drum.

Cap eliminates unnecessary vibrations from the bass drum.

Cap eliminates unnecessary vibrations from the bass drum.

Cap eliminates unnecessary vibrations from the bass drum.

Cap eliminates unnecessary vibrations from the bass drum.

Cap eliminates unnecessary vibrations from the bass drum.

Cap eliminates unnecessary vibrations from the bass drum.

Cap eliminates unnecessary vibrations from the bass drum.

Cap eliminates unnecessary vibrations from the bass drum.

| Tom Holder | | | | |
|-----------------|------------------|--------|--------------|--|
| Model No. | TH945A | TH940A | | |
| Rod | Short (for YESS) | Long | | |
| Tom Holder Base | Triple Mount | | Triple Mount | |

| Tom Clamp | | | | |
|-----------|------------------|------------------|---------|--------|
| Model No. | CL945LB | CL945B | CL940LB | CL940B |
| Rod | Short (for YESS) | Short (for YESS) | Long | Long |
| Pipe | Long | Short | Long | Short |

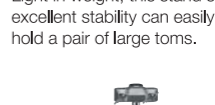
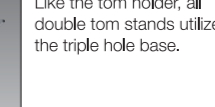
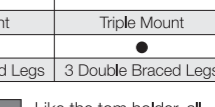
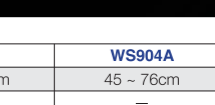
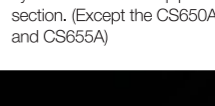
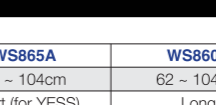
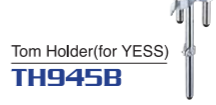

The TH904A fits into a cymbal stand's lower pipe section. (Except the CS650A and CS655A)

Double Tom Stand

Yamaha's double tom stands have long been recognized for their outstanding freedom in positioning drums. Their simple and durable design offers stable setting while the ball clamp system's ability to rotate 360 lets you position your toms or an additional snare drum exactly where you want.



Like the tom holder, all double tom stands utilize the triple hole base.



Double Tom Stand (for YESS)
WS955A NEW

Double Tom Stand
WS950A NEW

Double Tom Stand (for YESS)
WS865A NEW

Double Tom Stand
WS860A NEW

Double Tom Stand (for large diameter tom 14", 15", 16")
WS904A NEW
Light in weight, this stand's excellent stability can easily hold a pair of large toms.

Yamaha Drum HEXRACK

Yamaha System Hardware Analysis

The material is steel. But thanks to the blast processing applied to the surface, this beautiful new YAMAHA HEXRACK system (Registered of design) resists scratching, smudges and fingerprints. Beyond that, the hexagonal shape extends not only to the piping but also to the clamp rods. HEXRACK has the durability, performance and design value that have brought YAMAHA hardware renown everywhere drums and percussion are played. HEXRACK, together with the newly developed clamps, is the system that makes your dream setup a reality.



L-Rod (HXLR)

Hexrod Tom Mounts are included with all HXR configurations



Arm Clamp

Several clamps for securing tubes of different thickness (ϕ 15 – ϕ 34, including hexagonal tubes) are connected to the extended arm. These clamps can be used to secure tubes positioned far from each other. Each clamp has a gear joint, enabling fine angle adjustment.

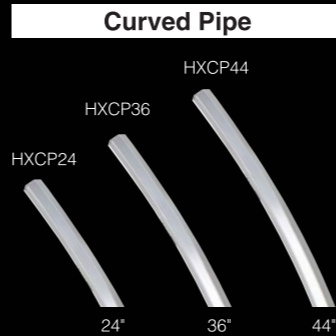

Curved Pipe



Cymbal Holder Clamp

22.2mm receptacles that will fit any Yamaha Cymbal Holder or mounting accessories is located in the top of each vertical leg.



Drum Arm Clamp (HXTC)

[PAT. PENDING] Thanks to the ball-mount structure—a distinguishing feature of YAMAHA hardware—you can adjust the angle to any degree you want. Because the clamp can easily be removed from (and attached to) the hexagonal tube, it can be used in any position. Moreover, the standard tom clamp (CL945 and others) can be attached, as well as the L-rod provided. (A diameter of 22.2 mm is required for attachment.)



Open Clamp

The open clamp is used to attach tubes having different thickness (ϕ 15 – ϕ 34, including hexagonal tubes) to the hexagonal tube. Although fine angle adjustment is possible with the gear joint, more stable setting can be achieved by limiting the movement only to the vertical direction.



Ball Clamp

The ball clamp is used to attach tubes having different thickness (ϕ 15 – ϕ 34, including hexagonal tubes) to the hexagonal tube. The ball clamp can be connected to the hexagonal tube using the ball-mount method for settings at various angles when used with the clamp gear joint.



Tom Clamp (HXTC)

The tom clamp is used through attachment of the L-rod or the tom holder. The tom clamp can be connected to the hexagonal tube using the ball-mount method for settings of any angle. (A diameter of 22.2mm is required for attachment.)



Cross Clamp

The cross clamp is used to connect two hexagonal tubes at 90-degree angles (for example, to connect a leg tube with a tube that has been horizontally set).



Logo Clip

The Logo clip, with an integrated level, is a convenient way to set an accurate level for your cross-tube.



Double Bass

The double bass is used to horizontally set two tubes at the same height – as in a double-bass configuration. Settings at various angles are possible when used with the clamp gear joint.



T-leg

| YAMAHA DRUM RACK ACCESSORY | | |
|----------------------------|-----------|-------------|
| CLAMPS | HEX PIPES | ATTACHMENTS |
| HXOC | HXCP44 | HXLC |
| HXBC | HXCP36 | HXLR |
| HXAC | HXCP24 | |
| HXDB | HXTL33 | |
| HXTC | HXTL23 | |
| HXCC | | |

HXR3L

The HXR3L is optimized for a 6 piece drum set configuration including floating Floor Toms.

| | |
|--------|-----|
| HXCP44 | x 1 |
| HXCP36 | x 1 |
| HXTL33 | x 2 |
| HXTL23 | x 1 |
| HXCC | x 4 |
| HXTC | x 4 |
| HXLC | x 1 |
| HXLR | x 4 |



HXR2L

The HXR2L is suitable for 5 piece drum set configuration including a floating floor tom.

| | |
|--------|-----|
| HXCP44 | x 1 |
| HXCP24 | x 1 |
| HXTL33 | x 2 |
| HXCC | x 3 |
| HXTC | x 3 |
| HXLC | x 1 |
| HXLR | x 3 |

ELECTRONIC PERCUSSION SYSTEM DTXTREME III

The legendary sound of Yamaha acoustic drums and some truly innovative technologies come together to form an extremely powerful electronic percussion system that lets you express yourself as never before.

Special Set

The Special configuration combines the innovative hex rack, four toms, snare, three cymbals, hi-hat, and kick. The cymbal, hi-hat, and kick pads have been refined to such a high degree that they feel even more realistic. The pads bring out the maximum capability of the module while the HEXRACK delivers solid support. It's a dramatic enhancement of functionality that'll create serious grooves and help players express themselves with more range than ever before.

Standard Set

The Standard configuration is a more compact version of DTXTREME III. By sharing the same module, it retains all of the features but has a smaller footprint for when space is at a premium.



*Foot pedal not included.
*Wiring not shown.



*Foot pedal not included.
*Wiring not shown.

ELECTRONIC PERCUSSION SYSTEM DTXTREME III Special set

- DTXT3 (Trigger Module)
- HXR4LD (Rack System)
- DTT3KSP1 (Pad Set)
- includes:
 - PCY155 (3Zone Cymbal Pad) x 1 KP125 (Kick Pad) x 1
 - PCY135 (3Zone Cymbal Pad) x 2 CH750 x 2 SS662
 - RHH135 (2Zone Hi-Hat Pad) x 1
- DTT3KSP2 (Pad Set)
- includes:
 - TP120SD (3Zone Pad) x 1 TP100 (3Zone Pad) x 4
 - CHH755 HS740A

ELECTRONIC PERCUSSION SYSTEM DTXTREME III Standard set

- DTXT3 (Trigger Module)
- RS130 (Rack System)
- DTT3KSTD1 (Pad Set)
- includes:
 - PCY155 (3Zone Cymbal Pad) x 1 KP125 (Kick Pad) x 1
 - PCY135 (3Zone Cymbal Pad) x 1 CH750 x 1 SS662
 - RHH135 (2Zone Hi-Hat Pad) x 1
- DTT3KSTD2 (Pad Set)
- includes:
 - TP120SD (3Zone Pad) x 1 TP100 (3Zone Pad) x 3
 - CHH755 HS650A



LIVE

DTXTREME III brings the power, superior tone, and sensitivity of our most popular acoustic drums to your fingertips for any live musical situation.



RECORDING

We combined superior sounds, sampling capability, and flexible connectivity into an easy to navigate interface to give drummers the ultimate tool for creating music in the studio.



PRACTICE

DTXTREME III makes practice fun and productive by giving you features that help you learn any style, and allow you to track the accuracy of your playing.

Artist



Akira Jimbo



Dave Weckl



John Robinson



Russ Miller



Tommy Aldridge

Artists' Demo Plays to Songs

DTXTREME III incorporates demo pieces played by the world's top pros, like Tommy Aldridge and Akira Jimbo, along with the solo work of Dave Weckl, John Robinson and Russ Miller. It also incorporates etudes for use in practice, making most of the DTXTREME III's realistic sound!

Drum Trigger Module
DTXT3



SOUND

The sound has been completely updated from the previous model, thanks to a newly developed sound engine equipped with a whopping 205MB of WAVE ROM including many of Yamaha's hi-quality AWM2 samples. Realism should be exactly that: realistic. Stored within DTXTREME III are 50 kits comprising expertly engineered drum and percussion sounds, all available for easy recall. With this system you'll have the sounds you need for any genre of music, anytime. We didn't stop there. The XA (Expanded Articulation) makes it possible to create a slightly different sampling sound with each stroke of a stick, even if you strike with precisely the same force. This provides more natural sound throughout the drumkit, from the quickest single-stroke or crush roll to the rattle of a close hi-hat and the legato of the ride cymbal. Also, DTXTREME III provides 51 variation effects that can be used for each kit in addition to reverb and chorus. At last, you can create original sounds that are exactly as you've imaged them.

SONG

DTXTREME III has demo songs played by Tommy Aldridge and Akira Jimbo, as well as drum-solo performances of Dave Weckl, John Robinson and Russ Miller. It also incorporates 44 compositions for your practice in various genres, including rock, jazz and hip-hop. DTXTREME III has enabled drum minus one—a feature unique to MIDI data—and the ability to practice only with the bass sound or at an adjusted tempo. Additionally, keyboard sounds can be transferred from the MOTIF. DTXTREME III offers dramatically realistic sound, due in part to the high-quality effects unit and "Keyboard Mega Voice Technology" incorporating various types of waves -- each of which has different performance method.

METRONOME

DTXTREME III is equipped with a metronome function that lets you set the click at adjustable intervals in accordance with the note or key signature. This function not only lets you set the pitch of each click sound but can also change the accent position of the clicking sound within the measure. Moreover, with its "measure-break" function you can set it leave out the clicks entirely for certain measures! DTXTREME III even has a training function called "groove check" that monitors the accuracy of the timing of impact against each pad. Further, while the rhythm gate function ensures the most accurate rimshots possible, you can have fun while you hone your skills and check the accuracy of your groove!

SAMPLING



By installing optional DIMM memory* the DTXTREME III can load up to MAX 512MB of external audio samples which you can then allocate to be played by the pads. For instance, you can transfer WAV/AIFF file stored on a PC into the DTXTREME III from a connected USB memory device and played just like an internal sound. Moreover, you can be edit it, process it with DSP effects, and trigger it from any pad. You can also sample directly from the AUX IN for recording external audio or do "re-sampling" where you record audio from the internal tone generator.

*DIMM is sold separately.

USB

USB connectivity means the ultimate in expandability for DTXTREME III. DTXTREME III comes with two USB terminals: USB TO DEVICE and USB TO HOST. By connecting USB TO DEVICE with an external memory device, the setup information for the main unit can be saved. This makes it easy to ensure your favorite setup for any situation, whether it's a live performance, a session or a jam. Directly connecting the main unit to a PC via USB TO HOST lets you link with DAW (music production) software and record the performance information as you go. Moreover, the data created using the DAW software can be replayed in the main unit.

DTXT3 Drum Trigger Module Main Specifications

- Tone Generator: AWM2 ●Polyphony: 64 notes ●Wave: 205MB (when converted to 16-bit linear format) ●Voice Preset: 1,115 drum voices, 211 melody voices (GM) ●Drum Kit Preset: 50 kits, User: 50 kits (in the Flash ROM), External: 1584 kits (or 99 x 16, in the external USB storage device) ●Effects: Reverb 9 types, Chorus 19 types, Variation 51 types (Drum Kit), Insertion 51 types (AUX IN/SAMPLING IN), Master Effect 9 types, Master EQ 5 bands ●Trigger Setup Preset: 7, User: 5 ●Pad songs: play, chase, cutoff, 4 songs (max), can be played simultaneously. ●Note Capacity: Approx. 152,000 notes ●Note Resolution: 480 pps (parts per quarter note) ●Song Recording type: Real time ●Song tracks: 2 tracks ●Songs Demo: 3 songs, Practice: 44 songs, Pad song: 40 songs, User: 50 songs ●Sequence Format: DTXTREME III Original Format, SMF format 0 ●Tempo: 30-300, Tap tempo ●Beat: 1/4-16/4, 1/8-16/8, 1/16-16/16 ●Timing: Accent, Quarter note, Eighth note, Sixteenth note, Triplet ●Click Voices: Preset: 8, User: 1 ●Training Functions: Measure break, Groove check, Rhythm gate ●Samples: 1,016 (for the User Voices) ●Sampling Sources: Audio input signals via AUX IN/SAMPLING IN, Audio output signals via OUTPUT (Resample) ●Sample Data Bits: 16bit ●Sampling Frequency: 44.1kHz, 22.05 kHz, 11.025 kHz, 5.5125 kHz (stereo/mono) ●Sampling Memory: Optionally installed, expandable to 512 MB (256 MB DIMM x 2 slots) *DIMMs are not installed to the instrument when shipped from the factory. ●Sample Length: Mono: 32MB, Stereo: 64MB ●Sampling Time: 44.1kHz: 25 min. 20 sec. 22.05kHz: 12 min. 40 sec. 11.025kHz: 25 min. 40 sec. 5.5125kHz: 55 min. 40 sec. ●Mono/Stereo ●Sample Format: DTXTREME III Original format, WAV, AIFF ●Controllers: - Stdsr, MASTER, PHONES, CLICK, ACCOMP, KICK, SNARE, TOM, CYMBAL, HI-HAT, MISC. - Data dial ●Displays: 240 x 64 dot graphic backlit LCD, 7-segment LED (3-digit) ●Connectors: - MIDI IN/OUT - USB TO DEVICE/TO HOST - OUTPUT L/MONO, R (standard phone jack) - DIGITAL OUT (EIAJ) CP1201, IEC60958, S/P DIF - INDIVIDUAL OUTPUT 1-6 (standard phone jack) - Trigger Input jacks 1-9, 12-15 (Standard stereo phone jack, L: Trigger Signal, R: Rim Switch) - Trigger Input jacks 10 and 11 (Standard stereo phone jack, L: Trigger Signal, R: Trigger Signal) - AUX IN/SAMPLING IN (Standard stereo phone jack) - PHONES (Standard stereo phone jack) - HI-HAT CONTROL (Standard stereo phone jack) - DC IN 16V
- Power Consumption: 18W ●Dimensions: Weight 334(W) x 285(D) x 96(H) mm, 3.6kg ●Accessories: AC Power Adaptor (Yamaha PA-300B, or an equivalent), Module stand, Module stand fasteners (4; included) Owner's Manual, Data List



The best of Yamaha's acclaimed acoustic drums

Feels Real, Sounds Real, Plays Real

Special Set

This set includes round cymbal pads, a snare pad with pad controller, real hi-hat pad, hi-hat stand, RS85 rack system, and more.



*Foot pedal not included.
*Wiring not shown.

DTXPRESS IV Special Set

- DTXP4 (Trigger Module)
- RS85 (Rack System)
- DTP4K2SP (Pad Set)
- includes:
- PCY155 (3-zone Cymbal Pad) x1 KP65 (Kick Pad) x1
- PCY135 (3-zone Cymbal Pad) x2 HS650 (Hi-Hat Stand) x1
- RHH135 (2-zone Hi-Hat Pad) x1
- TP65 (Single-zone Pad) x3
- TP100 (3-zone Pad) x1

DTXP4 Drum Trigger Module Main Specifications

●Tone Generator:AWM2 ●Maximum Polyphony:32 Notes ●Voice Memory:449 Voices/427 Drum, Percussion Voices, 22 Keyboard Voices ●Drum Kits:50 Preset, 20 User ●Effects:Reverb 19 Types, Master EQ ●Trigger Setup:7 Presets, 4 User ●Pad Controller: Snare Adjustment, Tuning, Tempo ●Song Memory:3 Demo Songs, 41 Training Songs, 19 Pad Songs,20 User Songs ●Recorder:Real Time ●Metronome:Tempo 30-300/min, Beat 1-9, Tap Tempo Function,Accent, 1/4, 1/8, 1/16, Triplet ●Training Functions:Measure Break, Groove Check, Rhythm Gate Function ●Display:16 Characters x 2 Lines Backlit LCD,3-Digit 7-Segment LED ●Connections: Trigger Input Jack 1, 5, 6, 7 (Standard Stereo Phone Jack L: Trigger, R: Rim Switch) Trigger Input 2/10, 3/11, 4/12, 8/9(Standard Stereo Phone Jack L: Trigger, R: Trigger) Hi-Hat Controller Jack, OUTPUT L/MONO R Jack (Standard Phone Jack) PHONES (Standard Stereo Phone Jack), AUX IN Jack (Stereo Mini Jack), MIDI OUT, DC IN ●Power Supply:DC12V ●Power Consumption:13.0 W ●Dimensions/Weight:252(W) X 147(D) X 52(H) mm/893g ●Accessories: AC Adaptor (PA-3C)

Standard Set

The Standard Set is compact but covers all the basics with 3-zone snare and hi-hat pads and 3-zone round cymbal pads.



*Foot pedal not included.
*Wiring not shown.

DTXPRESS IV Standard Set

- DTXP4 (Trigger Module)
- RS70 (Rack System)
- DTP4K2STD (Pad Set)
- includes:
- PCY135 (3-zone Cymbal Pad) x2 KP65 (Kick Pad) x1
- TP65 (Single-zone Pad) x3 HH65 (Hi-Hat Controller) x1
- TP65S (3-zone Pad) x2

Authentic Sound and Rich Expression

The DTXPRESS IV features a comprehensive selection of acoustic drum sounds including new audio waveforms of our acclaimed Oak Customs Series drums, along with a variety of percussion sounds, effects, and more are found in an expansive sound library that spans 427 voices. An AWM 2 tone generator delivers tone so natural and realistic that it will have your imagination running wild. 50 preset drum kits use a variety of different sounds to cover styles like rock, jazz, reggae, funk, Latin, and much more. And there is also memory supplied for 20 user kits so you can create and save your own original drum kits.

Feels Real, Plays Quiet

The way they feel, the way they play, the way they respond, it's all so close to acoustic drums. And all of that great sound and playability can be enjoyed in private, because the rubber pads keep actual sound output to a minimum. The rack system offers flexible pad placement and rock-solid stability while being compact and light weight. The DTXPRESS IV—its performance is nothing less than brilliant, and it excels in both practice and live situations.

Brand New Cymbal Pads

Ride, crash and hi-hat cymbal pads are all newly designed. Focusing more on feel and playability the new ride and crash pads are designed with a thinner inner cup that produces a more cymbal-like vibration that feels and plays closer to the real thing. DTX Series features a newly developed moving-type hi-hat pad that achieves the natural feel of pedal action.

It gives you fine control over the range of sounds, from quick-and-decisive to soft-and-subtle.



Precision Metronome and Sequencer

The DTXPRESS IV also features the same precision metronome system that received high acclaim when introduced in the DTXPLOTTER. The multi-beat metronome offers fine-tuning of subdivision beats, and individual voice and pitch settings for subdivision click sounds. Groove Check function, tap function, and rhythm gate function, which only allows notes played in time to be produced, are included and feature easy, normal, and pro-grade level settings. New to these great training functions is the Challenge Mode, which automatically adjusts the level setting to help you excel in your training. The built-in sequencer's 44 internal songs are great for sharpening your rhythm skills. You can mute the drum part and play along with the song, or mute everything but the bass part (Bass Solo function) and play along with just the bass part. You can also record your own performance data in real time and then listen to the playback. 19 pad songs are also included.

Drum Trigger Module DTXP4

The DTXPRESS IV features an excellent selection of Yamaha acoustic drum samples including new audio waveforms of Yamaha Oak Series acoustic drums that deliver powerful tone with a solid fundamental. The unit is also compatible with 3-zone pads and pad controller functions, giving it greater expressive power and playability. A large LED display makes viewing information, such as tempo or modes, easy to see at a glance.



AUX IN

With a CD, MP3, or other audio player connected to this jack, you can play along with your favorite recordings. (Drum parts cannot be muted on audio recordings.)



MIDI OUT

Transmit drum performance as MIDI data to an external device.

PHONES

Snake Cable Makes Setup Easy
Optimal cable lengths between the module and pads keep the wiring neat. Pad names are labeled on the plug ends for quick and easy wiring.

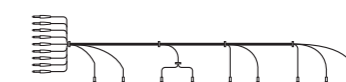

ELECTRONIC PERCUSSION SYSTEM

DTXPLOERER

Where Inspiration Sparks Exploration



Silent & Compact

The acoustic drum feel and very low pad noise make it the perfect drum kit for practicing at home.

The rack comes pre-assembled, so set up takes only a few minutes. When not in use, the rack folds up with the pads attached requiring less space for storage.



32 Preset Drum Kits

Rock, Funk, Jazz, Reggae, Latin Percussion, and more - the DTXPLOERER supplies you with an excellent selection of drum kits ready for immediate use. You can also create up to 10 customized drum kits of your own.



Sharpen Your Skills

The DTXPLOERER comes with 22 preset songs. You can either mute the drum track or play the bass part only to play along with the songs in a virtual session. Groove Check allows you to check your playing accuracy.



Precision Metronome is the Perfect Training Tool

Customize Metronome Settings

The metronome features a wide range of settings that let you customize its use to meet your specific needs. Create your own beat patterns, assign different click voices and subdivision clicks, and even set individual clock volume and tuning settings. You can also save your original click patterns to the 30 memory allocations.

Measure Break

Among other things, this function tells you if you are rushing or dragging your fills by muting the measures you select then checking what you play in those measures for accuracy.

| | Fills | |
|------------|-------|----------|
| DTXPLOERER | (OFF) | OK |
| Player | | Rushing |
| | | Dragging |

Ex: When beat = 4

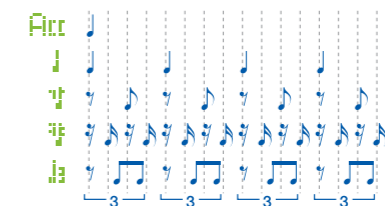

- Drum Voice (192 types)
- Volume (0 to 9)
- Tuning (-24 to +24)

Rhythm Gate

Another excellent training tool, Rhythm Gate mutes what you play if your timing falls outside of the three levels of timing accuracy. Sharpen your skills with Easy, Normal, or Pro levels.

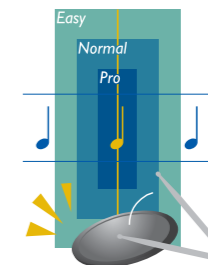

Groove Check

Groove Check provides instant feedback on your rhythmic accuracy as you play along with the songs or metronome.

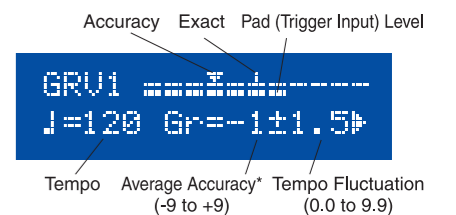

Tap Tempo

Simply tap in the tempo on the pad to set the tempo for the metronome or song.

Timer

Set the metronome operating time for 30-second intervals (30 to 600 seconds).



*Wiring not shown.

Foot Pedal Included

DTXPLOERER Set

- DTXPL (Drum Trigger Module) x1
- RS40 (Rack System) x1
- DTLK9 (Pad Set)
- includes:
 - TP65 (Single-zone Pad) x5
 - PCY65 (Single-zone Cymbal Pad) x2
 - KP65 (Kick Pad) x1
 - HH65 (Hi-Hat Controller) x1
 - FP6110A (Foot Pedal) x1

Drum Trigger Module

DTXPL

With eight buttons and a jog dial, the DTXPLOERER is very easy to use. Two click lamps (red and green) let you know the current metronome setting and timing. Terminals compatible with a 2-zone pad or a 3-zone pad (optional) are built-in. Optional DT20 Drum Triggers by Yamaha let you use the system with acoustic drums as well.

MIDI OUT

This jack works as an interface for recording MIDI data. Play the DTXPLOERER and your performance is converted into MIDI data.



PHONES AUX IN



Play along with your favorite Recordings. Connect a CD player, MP3 player, or other external audio device to this jack and play along with your favorite recordings. (The drum part from a CD player, MP3 player, or other such source can not be muted.)

Snake Cable Offers Quick and Easy Setup

Cable lengths are optimized to provide enough length to run from the module to each pad. The cables are bundled into a snake and cable ends are labeled with pad names so you can connect easily.

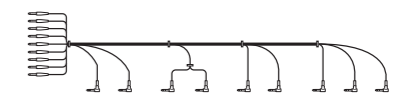

Easy To Store

The foldaway system offers easy storage of the unit with trigger module and pads attached to the rack. It's lightweight making it easier to move and stores conveniently in a small space.



- High quality sound in a simple, compact design
- Sounds and plays extremely close to acoustic drums with very low pad noise
- Perfect for drummers who want to practice at home and for beginners who want to start playing right away

DTXPL Drum Trigger Module Main Specifications

- Tone Generator: 16-bit AWM2
- Maximum Polyphony: 32 notes
- Voice Memory: 214 Voices(192 Drum, Percussion voices + 22 Keyboard voices)
- Drum Kits: 32 preset + 10 User
- Trigger Setup: 4 Presets + 1 User
- Song Memory: 22 Preset Songs (2 Demo Songs)
- Precision Metronome: Tempo/30~300, Beat/Quarter, Eighth, Sixteenth, Triplet, Accent, Click settings/Voice, Voice Tuning, Volume, Click Save/30 User Sets, Timer/30sec~600sec/Tap Tempo Function, Measure Break Function, Groove Check Function (Rhythm Gate Function)
- Connections: MIDI OUT Jack, Hi-Hat Controller Jack, OUTPUT L/MONO R Jack, PHONE Jack (standard stereo jack), AUX IN Jack (stereo mini jack), Trigger Input Jack L: Trigger Input, R: Rim Switch Input*Input 1 is compatible with 3-zone pads, Trigger Input Jack 2, 3, 4, 7 (standard monoaural jack: Trigger Input), Trigger Input Jack 8, 9 (standard stereo jack L, R: Trigger Input)
- Power Supply: DC12V
- Power Consumption: 3.2W
- Dimensions/Weight: 252(W) X 140(D) X 54(H) mm/835g
- Accessories: AC Adaptor (PA-3C)

Snare/Tom pad

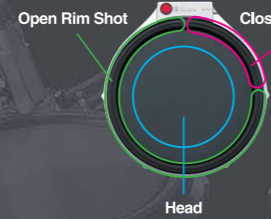

TP120SD 3-Zone Pad

The TP120SD is a 12" 3-zone pad, and the TP100 is a 10" 2-zone pad. Both pads offer open/closed rim and head playability. A pad controller provides easy tuning and snare adjustment. The TP100 attaches with a tom clamp.

TP100 3-Zone Pad

TP65S 3-Zone Pad

Don't let the compact size of the TP65S mislead you. Its 3-zone design lets you play head, open rim shot, and closed rim shot sounds all from the same pad. Authentic feel and excellent playability make it perfect for use as a snare pad, but it excels as a hi-hat pad as well.

TP65 Single-Zone Pad

This compact 8.5" single-zone pad is easy to play and offers a feel and rebound that is very close to an acoustic drum.

Cymbal pad

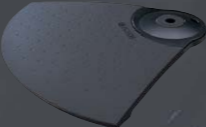

PCY155 3-Zone Pad

DTX Series offers a choice of 15" and 13" cymbal pads. Both sizes have the 3-zone structure in which each area of the pad, edge and bell produces a different tone. The natural "vibration" of the live cymbal sound can be faithfully reproduced.

PCY135 3-Zone Pad

PCY65 Single-Zone Pad

Mounted on a cymbal holder, this triangularly shaped single-zone cymbal pad offers an authentic feel with excellent silent characteristics.

Hi-Hat pad

Kick pad



RHH135 2-Zone Pad

DTXTREMEIII features a newly developed moving-type hi-hat pad that achieves the natural feel of pedal action. It gives you fine control over the range of sounds, from quick-and-decisive to soft-and-subtle. You can even play "foot splash"!

HH65 (Hi-Hat Controller)

Foot pedal can produce a full range of hi-hat effects such as full open, full closed, half open, and foot splash.

KP125

The kick pad is newly enlarged, so your playing will be rock-steady even when you use double footpedals. Also, due to the improved response, DTXREMEIII will faithfully reproduce the input of each beat.

KP65

Small pad provides plenty of space for a double pedal setup.

Rack

(for DTXREMEIII Special Set)

HXR4LD

This quality piece of equipment has been exclusively created for Special Set, and the hexagonal shape (HEX) provides maximum strength and stability. HEXRACK features pro-level specifications for players and situations that allow no compromise. With this system, you can make those fine adjustments to suit your needs.

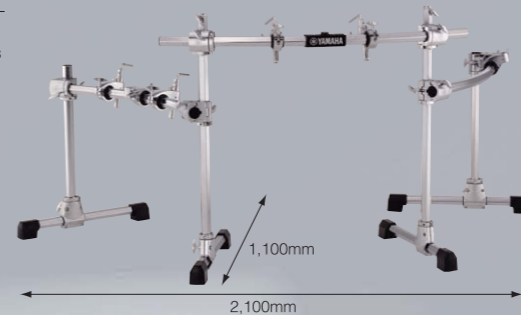

(for DTXREMEIII Standard Set)

RS130

Exclusively designed for Standard Set. Compact but surprisingly strong, it offers excellent stability. You can use it anywhere you want, from the live stage to the recording studio. The goal of playability has been achieved.



(for DTXPRESS IV Special Set)

RS85

The RS85 ships with the DTXPRESS IV Special set. It is very stable yet folds for compact storage. The stand features a CL940A ball clamp that allows total freedom of snare pad positioning.

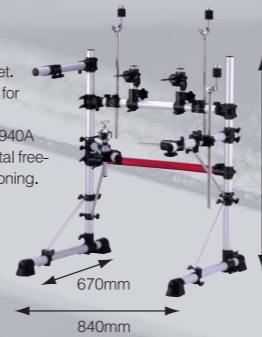

(for DTXPRESS IV Standard Set)

RS70

A hi-hat pad attaches to this rack system that is designed for use with the DTXPRESS IV Standard Set. Its compact design is highly durable.



(for DTXPLOTTER)

RS40

The RS40 ships with the DTXPLOTTER. The rack folds up with pads attached for easy storage, and its light weight makes it easy to transport.



*Dimensions are for a standard setting.

DTX Series Monitor Systems Include Satellite and Sub Woofer Speaker Systems

Systems feature left- and right-side satellite speakers (MS100DR: 40W x2, MS50DR: 20W x2) attached to the rack with the supplied SPAT1 attachments. The 100-watt MS100DR and 50-watt MS50DR bass reflex sub woofer units incorporate built-in power amplifiers that power the entire system. The MS100DR is equipped with a mix input plus line level outputs for connecting the system to a mixer or recording system for monitoring or for use in live or recording situations.

| Output | MS100DR | MS50DR |
|--------------------|---------|---------|
| Satellite Speakers | 40W x 2 | 20W x 2 |
| Sub Woofer | 100W | 50W |

DTX Series Monitor System MS100DR

Includes Speaker Cable x2, Phone Cable x2

*The HXTC (sold separately) is required for mounting on the HEXRACK.



DTX Series Monitor System MS50DR

Includes Speaker Cable x2, Phone Cable x2

*The HXTC (sold separately) is required for mounting on the HEXRACK.



For HEXRACK

Tom Clamp HXTC

The tom clamp is used through attachment of the L-rod or the tom holder. The tom clamp can be connected to the hexagonal tube using the ball-mount method for settings of any angle. (A diameter of 22.2mm is required for attachment.)



L-rod HXLR

Hexrod Tom Mounts are included with all HXR configurations



For RS Series

Tom Holder (w/Clamp) TPCL65



Tom Holder (w/Clamp) TPCL150



Speaker Attachment (L/R side set) SPAT1

SPAT1 holds a pair of Yamaha (MSP3, MS101 III) or similar speakers.



* Not intended for use with speakers weighing over 5kg

Cymbal Attachment (w/Clamp) CYAT65



Cymbal Attachment (w/Clamp) CYAT150



Drum Trigger DT10



Drum Trigger DT20



* Attaches to the shell or head on an acoustic drum and transmits a trigger signal to the drum trigger module.

USB-MIDI INTERFACE UX16

This bus-powered USB MIDI interface does not require a power adaptor and offers 16 OUT/16 IN MIDI Channel control.



Wood Hoop



SIZE : 16" SIZE : 14" SIZE : 13" SIZE : 12" SIZE : 10" SIZE : 8"

| Model | Application | Diameter | Holes |
|---------|-------------|----------|-------|
| VH0805T | Tom Tom | 8" | 5 |
| VH1006T | Tom Tom | 10" | 6 |
| VH1206T | Tom Tom | 12" | 6 |
| VH1306T | Tom Tom | 13" | 6 |
| VH1408T | Tom Tom | 14" | 8 |
| VH1408F | Floor Tom | 14" | 8 |

| Model | Application | Diameter | Holes |
|---------|-------------|----------|-------|
| VH1508T | Tom Tom | 15" | 8 |
| VH1608T | Tom Tom | 16" | 8 |
| VH1608F | Floor Tom | 16" | 8 |
| VH1808F | Floor Tom | 18" | 8 |
| VH1408S | Snare | 14" | 8 |
| VH1410S | Snare | 14" | 10 |

Snares

HI-CARBON STEEL SNARES

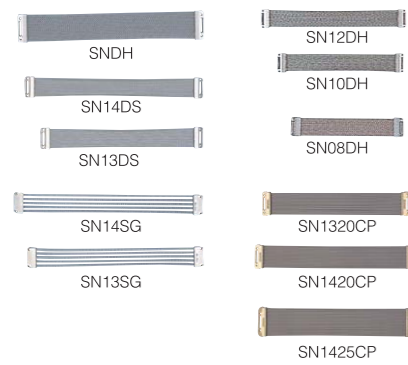

STAINLESS STEEL SNARES

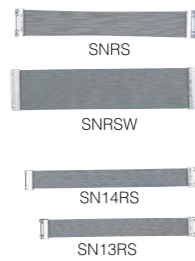

| | Model | Strands | Type |
|-----------------|------------|-----------------------|-----------------------|
| Hi-carbon Steel | SNDH | 20 strands | Short |
| | SN14DS | 14 strands | Short |
| | SN13DS | 14 strands | Short |
| | SN14SG | 10 strands | Short |
| | SN13SG | 10 strands | Short |
| | SN12DH | 14 strands | Short |
| | SN10DH | 14 strands | Short |
| | SN08DH | 14 strands | Short |
| | SNDL | 20 strands | Long |
| | SND | 20 strands | Short |
| | SN1314 | 14 strands | Short |
| | SN1425 | 25 strands | Short |
| | SN1525 | 25 strands | Short |
| | SN1320CP | 20 strands | Coated Finish / Short |
| SN1420CP | 20 strands | Coated Finish / Short | |
| SN1425CP | 25 strands | Coated Finish / Short | |
| Stainless Steel | SNRS | 20 strands | Short |
| | SNRSW | 30 strands | Short |
| | SN14RS | 14 strands | Short |
| | SN13RS | 14 strands | Short |
| | SN14SW | 14 strands | Short |
| | SN14SWL | 14 strands | Long |
| | SNE* | 8 strands | Long |

* SNE: Nylon coated wire

Cord & Snare Tape



| Model No. | Name |
|-----------|---------------|
| SNT10 | Snare tape |
| SNC10 | Snare strings |

Ring Mute



| Model No. | Name | For use with |
|-----------|--------------------------------|--------------|
| MU13SG | Ring mute (Width 18mm) (Black) | 13" |
| MU14SG | Ring mute (Width 18mm) (Black) | 14" |
| MU13S2 | Ring mute (Width 18mm) | 13" |
| MU14S2 | Ring mute (Width 18mm) | 14" |
| MU14S1 | Ring mute (Width 36mm) | 14" |

Tuning Key



| Model No. | Name |
|-----------|----------------------------|
| DK15 | Tuning key |
| DK20 | Tuning key |
| DK40R | Tuning key (w/ hex wrench) |



Drum Trigger

DT10

Attach the DT10 sensor to a drum shell or head for transmitting trigger signals to a DTX module.



DT20

With the DT20 sensor attached and connected to a DTX trigger module, your training pad turns into an electronic drum making practice sessions that much more enjoyable.



DT30

DT30S (5 piece set)

With the DT30 sensor attached and connected to a DTX trigger module, your quiet rubber pad turns into an electronic drum.

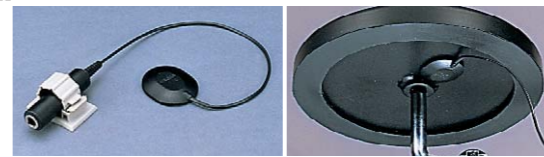

* See pages 51-58 for more information on the DTX series.

Yamaha Drum Trigger Compatibility

Refer to the accompanying chart for compatibility with Yamaha DT series drum triggers and trigger modules. "O" indicates compatibility, "X" indicates incompatibility.

* Some DT triggers may not be sensitive enough for use with some training pads.

| | DT10 | DT20 | DT30 |
|--------------------------|--------------------|------|------|
| Acoustic Drum Shell | O | O | X |
| Acoustic Drum Head | O | X | X |
| Head Type Training Pad | X | O | O |
| Rubber Type Training Pad | X | X | O |
| Shell Type Training Pad | X | O | O |
| Cymbal Type Training Pad | X | X | X |
| Sensitivity | DT10 < DT20 < DT30 | | |

Retrofit Kit

Enhance The sustain on your drums with a YESS system upgrade retrofit kit.

Tom Tom
RK TT



Floor Tom
RK FT



*YESS attachments are only available for use on previous Maple Custom drums and Recording Custom drums.

FACTORY PARTS

Bass Drum Leg



| Model No. | Name | For use with |
|-----------|-------------------------|---|
| PBLALN | Spur left side | Previous Absolute Series, Maple Custom, Recording Custom, Previous Oak Custom (24", 22", 20") |
| PBLARN | Spur right side | |
| PBLAN2L | Spur left side for 18" | Previous Absolute Series, Maple Custom, Previous Oak Custom (18") |
| PBLAN2R | Spur right side for 18" | |

Bass Drum Leg Base



| Model No. | Name | For use with |
|-----------|------------------|---|
| PBBL | Spur riser left | Previous Absolute Series, Maple Custom, Recording Custom, Previous Oak Custom |
| PBBR | Spur riser right | |

Claw Hook



| Model No. | Name | For use with |
|-----------|----------------------------------|--|
| PCH2 | BD claw hook | All bass drums except for those in the new Absolute Series |
| PBDTR115 | 115 (for bass drum) | 115mm overall length (w/o head) for new Absolute Series bass drums / includes plastic spacers, washers |
| PBDTR100 | 100 (for bass drum) | 100mm overall length (w/o head) for new Absolute Series bass drums / includes plastic spacers, washers |
| PTR125 | 125 (for bass drum) | 125mm overall length (w/o head) for new Absolute Series bass drums / includes plastic spacers, washers |
| PTR100 | 100 (for bass drum) | 100mm overall length (w/o head) for new Absolute Series bass drums / includes plastic spacers, washers |
| PRI3 | Rubber insert for bass drum hoop | All bass drums |

Bass Drum Tension Rods



BD Hoop Clamp Rubber



Foot Pedal Chain & Belt Beater Stopper FP Spring Bolt, Nut FP Spring Ring FP Spring

| | | | | |
|-----------|----------------------------------|----------------------------------|--|--|
| | | | | |
| Model No. | Name | For use with | | |
| PBL4 | Belt with two plates | FP9315, DFP9315, FP8115, DFP8115 | | |
| PFCS2 | Single chain | FP8215, DFP8215, FP7210A | | |
| PFCW2 | Double chain | FP9315, DFP9315, DFP9315L | | |
| PBS | Beater stopper | FP9415, DFP9415, FP9315, DFP9315 | | |
| PSBB | Bolt Assy* for spring adjustment | All foot pedals except FP7210A | | |
| PSR | FP spring ring | All foot pedals | | |
| PFSD | FP spring | All foot pedals | | |

FP Base Plate Screw FP Universal Joint FP Soft Case Drum key Wrench

| | | | |
|-----------|------------------------------------|----------------------------------|--|
| | | | |
| Model No. | Name | For use with | |
| PSB1016 | Black bolt underside of base plate | 9415, 9315, 8215 series, DFP8115 | |
| PUJ5 | Universal joint assembly | All DFP | |
| PSC | Pedal soft case | — | |
| PDW | Drum key & hex wrench | All foot pedals | |

Drum Key Bolts

| | | | |
|-----------|--|--------------------------------|--|
| | | | |
| Model No. | Name | For use with | |
| PDB812 | Key bolts (for beater) | All foot pedals | |
| PDB612A | Key bolts (for spring tension) | All foot pedals except FP7210A | |
| PDB608 | Key bolts (for double pedal shaft/M6x8mm) | All hi-hat pedals | |
| PDB510 | Key bolts (for double pedal shaft/M5x10mm) | All hi-hat pedals | |

Floor Tom Leg Lugnuts Metal Washers

| | | |
|-----------|-------------------------|----------------|
| | | |
| Model No. | Name | For use with |
| PFLA21 | Floor tom leg assembly | All floor toms |
| PLNT4 | Lugnuts (Standard) | |
| PLNT5 | Lugnuts (Self-locking) | |
| PMW5 | Washers for tension rod | |

Rim Tension Rods

| | | |
|-----------|------|---|
| | | |
| Model No. | Name | For use with |
| PTR70 | 70 | 70mm overall length (w/o head) / includes washers |
| PTR60 | 60 | 60mm overall length (w/o head) / includes washers |
| PTR50 | 50 | 50mm overall length (w/o head) / includes washers |
| PTR40 | 40 | 40mm overall length (w/o head) / includes washers |

Snare Drum Hoop

| | | | | | |
|------------|---------------------------------|-----------|----------------|-------|---|
| | | | | | |
| Model No. | Name | Thickness | Diameter(inch) | Holes | For use with |
| PDH1410H | Dynahoop | 2.3mm | 14 | 10 | NSD087, NSD085, BMSD1465, BMSD1455, FSD1465, |
| PDH1410HS | Dynahoop (Bottom) | 2.3mm | 14 | 10 | FSD1455, SD6106, SD6105, SD6103, SD255NC, SD655RH |
| PAH1410H2 | Aluminum die-cast hoop | 3.0mm | 14 | 10 | — |
| PAH1410HSR | Aluminum die-cast hoop (Bottom) | 3.0mm | 14 | 10 | — |
| PRH148H | Triple flange hoop | 1.6mm | 14 | 8 | — |
| PRH148HS | Triple flange hoop (Bottom) | 1.6mm | 14 | 8 | — |
| PRH1410H | Triple flange hoop | 1.6mm | 14 | 10 | — |
| PRH1410HS | Triple flange hoop (Bottom) | 1.6mm | 14 | 10 | — |

Snare Drum Lug

| | | | | |
|-----------|---------------------------|-------|----------------|---|
| | | | | |
| Model No. | Name | Shape | Finish | For use with |
| PLUNGL | Absolute lug | Round | Gold | MSD1470EJ |
| PLUNCR | Absolute lug | Round | Chrome | ASD1460BC, WSD1455SE, ASD01**, BSD01**, WSD01** |
| PLU2GL | Small lug | Cube | Gold | Maple Custom snare drums, MSD14ADW, MSD13ADW, FSD1455KS |
| PLU2CR | Small lug | Cube | Chrome | Copper snare drums, WSD13AJ, Steve Gadd snare drums, SD355DW, SD655ARH, WSD1455SH, SD2455JC |
| PLU2CR2 | Small lug | Cube | Special chrome | BSD1550JR, BSD1455NJR |
| PLU3N | Small lug | Round | Chrome | Oak Custom snare drums |
| PLUSD | One-piece lug | — | Chrome | Stage Custom snare drums, SD4106, SD4105, SD2076B, SD2075B, SD465AMK, SD455AMK, SD255ANC |
| PLUSDP | One-piece lug for piccolo | — | Chrome | SD4103, SD435ADG |

Snare Drum Strainer

| | | | |
|-----------|------------------|--------|---------------------|
| | | | |
| Model No. | Name | Finish | Application |
| PSAHLN | H type | Chrome | Release side |
| PSAGRM | G type | Chrome | Butt side |
| PSAPCRLM | P type | Chrome | Release side |
| PSAPCRRM | P type | Chrome | Butt side |
| PSAP2L | P type | Gold | Release side |
| PSAP2R | P type | Gold | Butt side |
| PSAB6L | B type | Chrome | Release side |
| PSAB3NR | B type | Chrome | Butt side |
| PSAID | Snare attachment | Chrome | Detachable Strainer |

Clutch Wing Bolt Rod Clutch Felt Washers Metal Washer Felt & Rubber Washer

| | | |
|-----------|-------------------------|-----------------------|
| | | |
| Model No. | Name | For use with |
| PWB612 | Wing bolt (M6x12mm) | All hi-hat stands |
| PERAA | Standard hi-hat rod | All hi-hat stands |
| EX910 | Extension rod 4" | All hi-hat stands |
| PFW22 | Felt washers | All hi-hat stands |
| PMWHS | Metal washer | All hi-hat stands |
| PFW54 | Cymbal support (Felt) | HS840, HS740A, HS650A |
| PRW54 | Cymbal support (Rubber) | HS1100, HS1000, HS950 |

Cymbal Stand Tilter Sleeves Cymbal Stand Felt Washers Cymbal Stand Nut Boom Arm Clamp

| | | |
|-----------|-----------------------------|---------------------|
| | | |
| Model No. | Name | For use with |
| PTS3A | Tilter sleeves (Bolt cover) | All cymbal stands |
| PFW40 | Felt washers | All cymbal stands |
| PYN8S | Wing nut (M8) | — |
| PBCA | Position clamp for boom arm | CS945, CS845, CS755 |

Wing Bolt Wing Nut Position Clamp

| | | |
|-----------|--------------------------------|---|
| | | |
| Model No. | Name | For use with |
| PWB8A | Wing bolt (M8x15mm) | |
| PWB8LA | Wing bolt (M8x15mm/Large size) | |
| PWN8A | Wing nut (M8) | |
| PPC4A | Position clamp | All cymbal holders, All tom holders, All tom clamps (22.2mm diameter) |

Rubber Feet Tom Holder Cap

| | | |
|-----------|---------------------------|--|
| | | |
| Model No. | Name | For use with |
| PRF11 | Rubber feet (Large size) | HS840, SS840, SS940, CS840, CS845, CS925, CS940, CS945, WS860, WS865, WS904, WS950, WS955, DS950, DS1100 |
| PRF10 | Rubber feet (Medium size) | HS740A, SS740A, CS750, CS755, WS714, WS760, WS765, WS770, WS775, DS750 |
| PTHP | Cap | All tom holders |